



**WACKER
NEUSON**

0620776	100
08.2016	

**Diaphragm Pumps
Membran-Schmutzwasserpumpen
Bombas de Diafragma
Pompes à diaphragme**

PDI3A(I)

**Parts Book
Ersatzteile
Lista de Repuestos
Liste de Pièces de Rechange**

www.wackerneuson.com

A nameplate listing the Model Number, Item Number, Revision, and Serial Number is attached to each unit. Please record the information found on this plate so it will be available should the nameplate become lost or damaged. When ordering parts or requesting service information, you will always be asked to specify the model, item number, revision number, and serial number of the unit.

Ein Typenschild mit Typ, Artikelnummer, Version und Maschinen-Nummer ist an jedem Gerät angebracht. Die Daten von diesem Schild bitte notieren, damit sie auch bei Verlust oder Beschädigung des Schildes noch vorhanden sind. Der Typ, die Artikel-Nummer, die Versions- Nummer und die Maschinen-Nummer sind bei der Ersatzteilbestellung oder Nachfragen bezüglich Service-Informationen stets erforderlich.

Una placa de identificación con el modelo, número de referencia, nivel de revisión y número de serie ha sido añadida en cada máquina. Favor de anotar los datos en la placa en caso de que la placa de identificación sea destruida o perdida. En todos los pedidos para repuestos necesita siempre el modelo, el número de referencia, el nivel de revisión y el número de serie de la máquina en cuestión.

Une plaque signalétique mentionnant le modèle, le numéro de référence, le niveau de révision et le numéro de série est fixée sur chaque machine. Veuillez noter les informations relevées sur cette plaque de façon à ce qu'elles soient toujours disponibles si la plaque signalétique venait à être perdue ou endommagée. Lorsque vous commandez des pièces détachées ou vous sollicitez des informations après-vente, on vous demandera toujours de préciser le modèle, le numéro de référence, le niveau de révision et le numéro de série de la machine.

***My machine's numbers are / Die Nummern meines Gerätes sind /
 Los números de mi máquina son / Les numéros de ma machine son :***

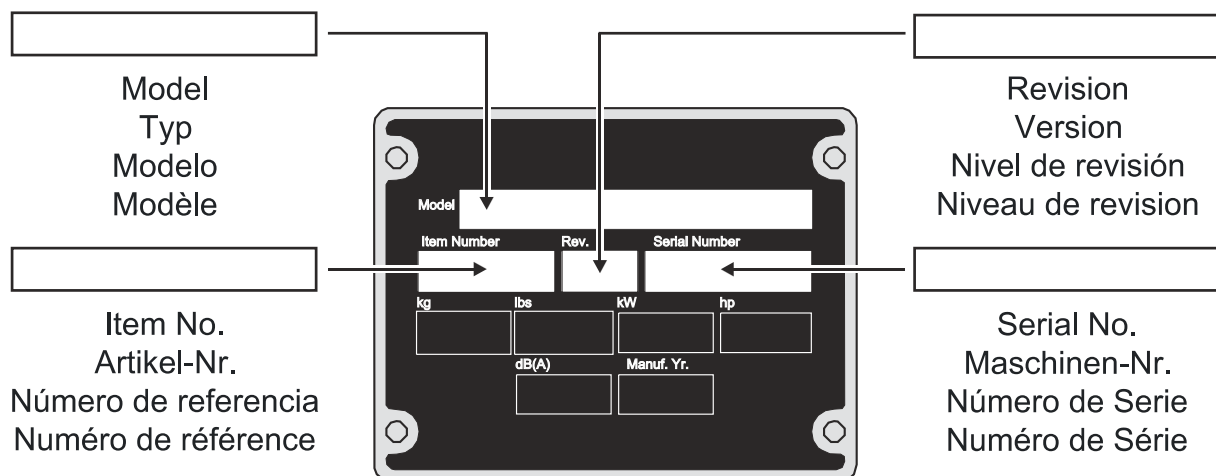

Part Numbers appearing in boldface type are recommended spare parts. This means that these parts are subject to wear under normal operating conditions and may require periodic service or replacement. It is recommended that these items be stocked to meet the expected service requirements of this model. Actual stocking quantities of these and other parts used in more extensive repairs will depend on the service practices of each customer.

Bei den in den Ersatzteillisten fettgedruckten Nummern handelt es sich um empfohlene Ersatzteile. Dies bedeutet, daß diese Teile bei normalen Anwendungsbedingungen natürlicher Abnutzung ausgesetzt sind und gelegentlich ersetzt oder überarbeitet werden müssen. Es wird geraten, diese Teile auf Lager bereit zu haben, um für Service-Arbeiten an diesem Gerät vorbereitet zu sein. Lagerbestände für diese und andere Teile, welche für ausgiebigere Reparaturarbeiten benötigt werden, können je nach Service-Gewohnheiten der einzelnen Kunden variieren.

Los números de partes en negritas en las Listas Ilustradas de Partes son los repuestos recomendados, ésto quiere decir que estas partes se desgastarán bajo circunstancias de funcionamiento normales y pueden requerir servicio periódico o su reemplazo. Se recomienda que el cliente mantenga un abastecimiento adecuado de estas partes para poder satisfacer la demanda requerida por el servicio a la máquina. La cantidad de repuestos que el cliente necesitará para reparaciones dependerá de la póliza de servicio de cada cliente.

Les numéros de pièces imprimés en caractères gras dans les Listes des Pièces Détachées de ce manuel sont les pièces détachées recommandées par la Wacker. Cela veut dire que ces pièces sont sujettes à usure dans des conditions de travail normales et peuvent nécessiter de l'entretien ou leur remplacement. Nous recommandons que vous disposez d'un stock de ces pièces pour pouvoir satisfaire la demande d'entretien de cette machine. Le client doit décider lui-même de la quantité exacte de pièces de rechange qu'il disposera dans ses stocks.

Pump cpl. Pumpe kpl. Bomba compl. Pompe compl.	8
Gearbox cpl. Getriebegehäuse kpl. Caja de engranajes compl. Boîte de vitesses compl.	12
Plunger/Housing Plunger/Gehäuse Émbolo de inyección/Caja Plongeur/Carter	16
Labels Aufkleber Calcomanias Autocollants	18
Engine-Honda Honda-Motor Motor Honda Moteur Honda	21
Starter Starter Arrancador Démarreur	22
Ignition Coil Zündspule Bobina de Encendido Bobine d'Allumage	24
Labels Aufkleber Calcomanias Autocollants	26
Cylinder Head Zylinderkopf Culata Culasse	28
Camshaft Nockenwelle Arbol de levas Arbre à cames	30
Engine Block Motor Motor Moteur	32
Crankcase Cover Kurbelgehäusedeckel Tapa del Carter Couvercle de Carter	34
Piston Kolben Pistón Piston	36
Crankshaft Kurbelwelle Cigüeñal Vilebrequin	38

Flywheel Schwungrad Volante Volant	40
Blower Housing Lüftergehäuse Cubierta Bouclier	42
Throttle Control Gasregler Acelerador Commande des Gaz	44
Carburetor cpl. Vergaser kpl. Carburador compl. Carburateur compl.	46
Fuel Tank cpl. Kraftstofftank kpl. Depósito de Combustible compl. Réservoir de carburant compl.	50
Air Cleaner Luftfilter Filtro del Aire Filtre à Air	52
Muffler Auspufftopf Silenciador Pot d'échappement	54

Pump cpl.
Pumpe kpl.
Bomba compl.
Pompe compl.

PD13A(I)

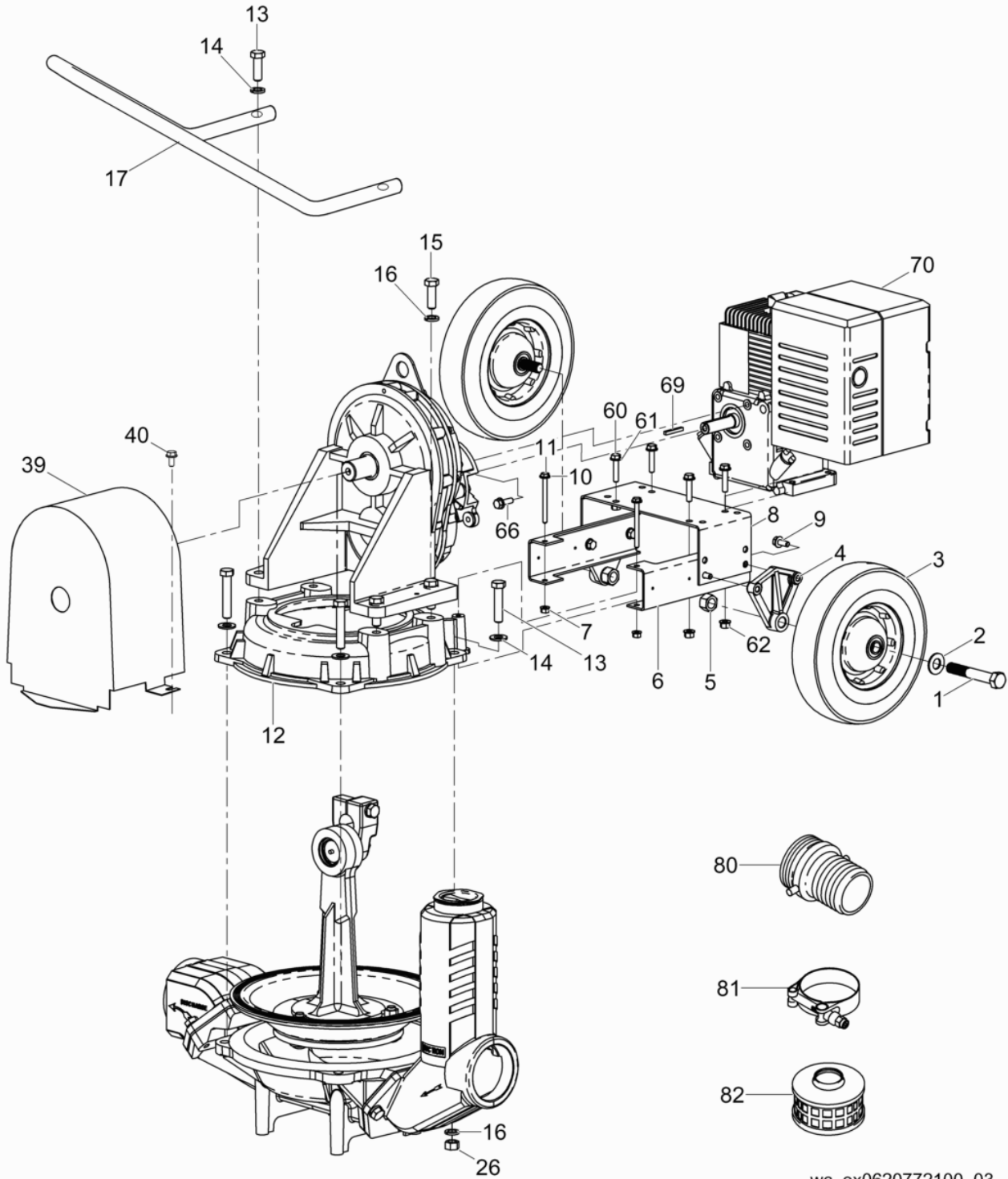

Ref. Pos.	Part No. Artikel Nr.	Qty. St.	Description Beschreibung	Descripción Description	Measurem./Abm.	Norm
					Torque/Drehm.	Sealant Schmierstoff
1	0179852	2	Bolt Bolzen	Perno Boulon	5/8-18 x 4,00in	
2	0179853	2	Washer Scheibe	Arandela Rondelle	5/8in	
3	0179854	2	Wheel Rad	Rueda Roue		
4	0179855	2	Bracket Konsole	Soporte Support		
5	0179856	2	Nut Mutter	Tuerca Écrou	5/8in-18	
6	0179857	2	Mount Konsole	Ménsula Support		
7	0179858	2	Hexagon nut Sechskantmutter	Tuerca hexagonal Écrou hexagonal	1/4in-20	
8	0179859	1	Engine mount Motorträger	Soporte de motor Support pour moteur		
9	0179860	4	Flange bolt Flanschbolzen	Perno de reborde Boulon à bride	5/16-18 x 3/4in	
10	0179861	2	Washer Scheibe	Arandela Rondelle	1/4in	
11	0179862	2	Bolt Bolzen	Perno Boulon	1/4-20 x 3,00in	
12	0179863	1	Pump base Konsole	Ménsula Console		
13	0179865	6	Bolt Bolzen	Perno Boulon	1/2-13 x 2-1/4in	
14	0179866	6	Flat washer Scheibe	Arandela elástica Rondelle de ressort	1/2in	
15	0179867	2	Bolt Bolzen	Perno Boulon	1/2-13 x 1-1/2in	
16	0179869	2	Lock washer Federring	Federring Rondelle de ressort	1/2in	
17	0179871	1	Handle Handgriff	Manija Poignée		
39	0180263	1	Guard Schutz	Protector Protection		
40	0180264	2	Hexagonal head cap screw Sechskantschraube	Tornillo hexagonal Boulon à tête hexagonale	1/4-20 x 3/4in	
60	0182014	4	Screw Schraube	Tornillo Vis	5/16-18 x 1-1/2in	
61	0182015	4	Flat washer Unterlegscheibe	Arandela plana Rondelle	5/16in	
62	0182016	4	Hexagon nut Sechskantmutter	Tuerca hexagonal Écrou hexagonal	5/16in-18	
66	0025566	4	Hexagonal head cap screw Sechskantschraube	Tornillo hexagonal Vis à tête hexagonale	5/16in-24UNF-2A x 1in 18Nm/13ft.lbs	
69	0180294	1	Key Passfeder	Llave Clé	3/16 x 3/16 x 1-1/2	
70	0112136	1	Engine-Honda Honda-Motor	Motor Honda Moteur Honda		

Pump cpl.
Pumpe kpl.
Bomba compl.
Pompe compl.

PD13A(I)

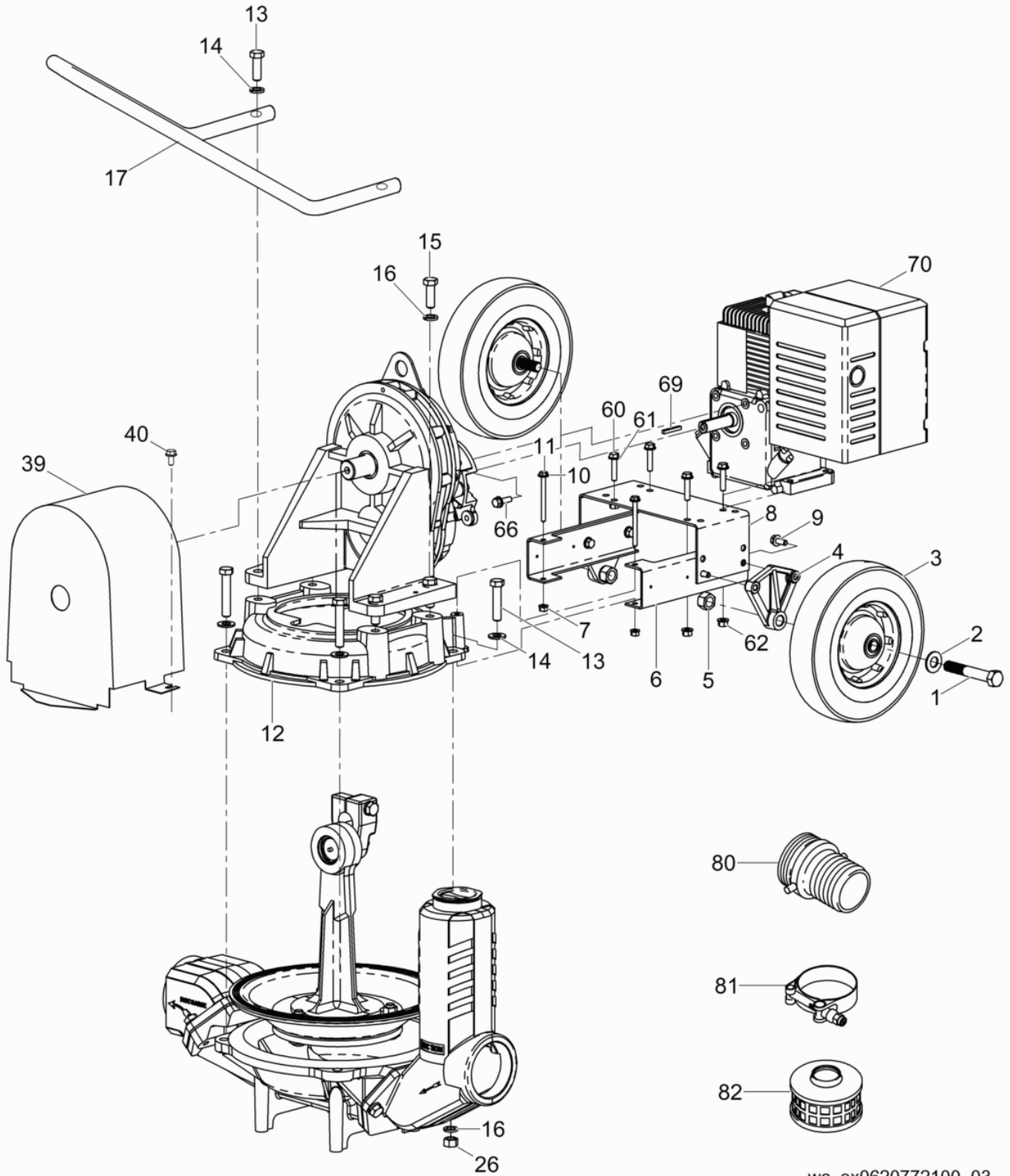

wc_ex0620772100_03

Ref. Pos.	Part No. Artikel Nr.	Qty. St.	Description Beschreibung	Descripción Description	Measurem./Abm.	Norm
					Torque/Drehm.	Sealant Schmierstoff
80	0028071	1	Hose coupling Kupplungsstück	Acoplamiento de manguera Accouplement à tuyau	76mm/3in	
81	0028699	1	Clamp Schlauchselle	Abrazadera Agrafe	3-7/16in	
82	0183529	1	Strainer Sieb	Tamizador Tamis	3in	

Gearbox cpl.
Getriebegehäuse kpl.
Caja de engranajes compl.
Boîte de vitesses compl.

PDI3A(I)

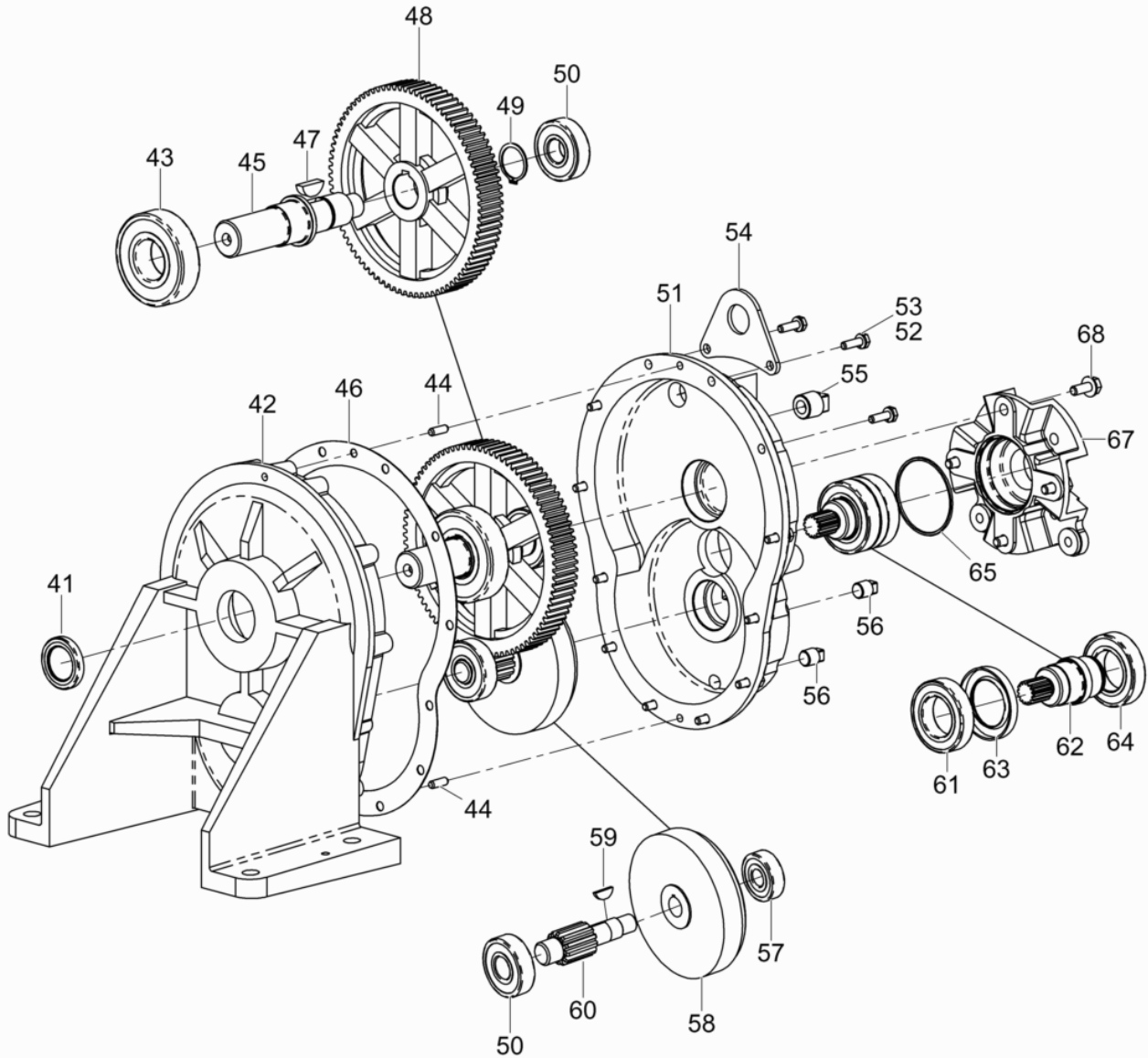

wc_ex0620769100_01

Ref. Pos.	Part No. Artikel Nr.	Qty. St.	Description Beschreibung	Descripción Description	Measurement/Abm.	Norm
					Torque/Drehm.	Sealant Schmierstoff
41	0180265	1	Oil seal Öldichtung	Empaque de aceite Joint d'huile		
42	0180266	1	Gearbox Getriebegehäuse	Caja de engranajes Boîte de vitesses		
43	0180267	1	Bearing Lager	Rodamiento Roulement		
44	0180268	2	Dowel pin Paßstift	Espiga Cheville	1/4 x 1in	
45	0180269	1	Shaft Welle	Eje Arbre		
46	0180270	1	Gasket Dichtung	Junta Joint		
47	0180271	1	Woodruff key Woodruffkeil	Chaveta Woodruff Clavette Woodruff	5/16 x 1,00in	
48	0180272	1	Gear Zahnrad	Engranaje Engrenage		
49	0180273	1	Retaining ring Sicherungsring	Anillo de retención Bague d'arrêt	1-1/8in	
50	0180274	2	Bearing Lager	Rodamiento Roulement		
51	0180275	1	Cover Deckel	Tapa Couvercle		
52	0180276	12	Lock washer Federring	Federring Rondelle de ressort	1/4in	
53	0180277	12	Bolt w/washer Kit (12) Bolzen mit Scheibensatz (12)	Juego de Perno con arandela (12) Jue de Boulon avec rondelle (1)	1/4-20 x 7/8in	
54	0180278	1	Lifting bracket Hebebügel	Ménsula alzadora Support de relèvement		
55	0180279	1	Plug Stopfen	Tapón Bouchon	1/2in NPT	
56	0180280	2	Plug Stopfen	Tapón Bouchon	1/4in NPT	
57	0180281	1	Bearing Lager	Rodamiento Roulement		
58	0180282	1	Internal gear Innenrad	Engranaje interior Roue intérieure		
59	0180283	1	Woodruff key Woodruffkeil	Chaveta Woodruff Clavette Woodruff	1/8 x 3/4in	
60	0180284	1	Shaft Welle	Eje Arbre		
61	0180285	1	Bearing Lager	Rodamiento Roulement		
62	0180286	1	Pinion gear Ritzel	Piñon diferencial Pignon		
63	0180288	1	Oil seal Öldichtung	Empaque de aceite Joint d'huile		
64	0180289	1	Bearing Lager	Rodamiento Roulement		
65	0180290	1	O-Ring O-Ring	Anillo-O Joint torique		

Gearbox cpl.
Getriebegehäuse kpl.
Caja de engranajes compl.
Boîte de vitesses compl.

PDI3A(I)

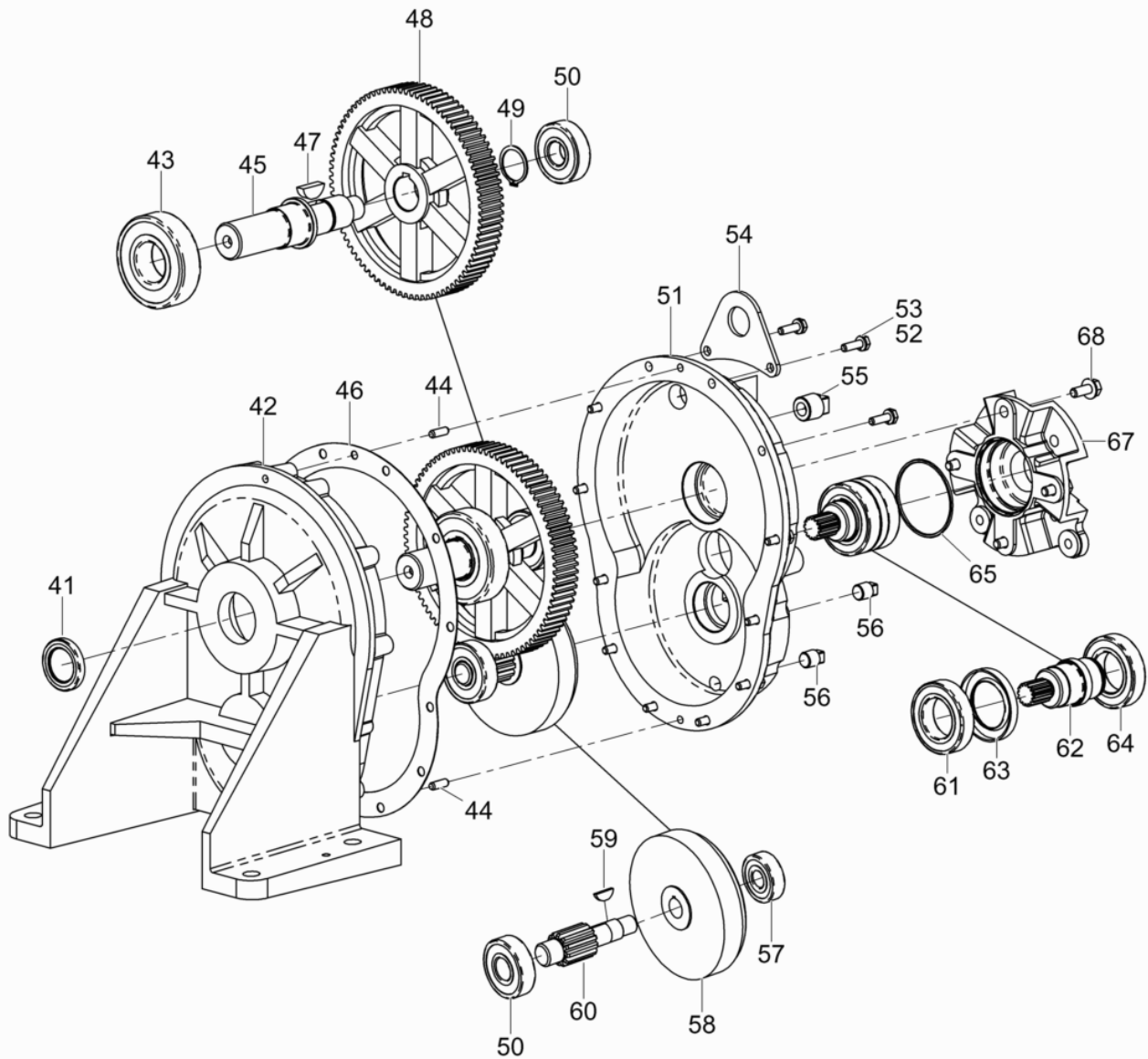

wc_ex0620769100_01

Ref. Pos.	Part No. Artikel Nr.	Qty. St.	Description Beschreibung	Descripción Description	Measurem./Abm.	Norm
					Torque/Drehm.	Sealant Schmierstoff
67	0180292	1	Adapter Adapter	Adaptador Raccord		
68	0179860	4	Flange bolt Flanschbolzen	Perno de reborde Boulon à bride	5/16-18 x 3/4in	
72	0180297	1	Gearbox cpl. Getriebegehäuse kpl.	Caja de engranajes compl. Boîte de vitesses compl.		

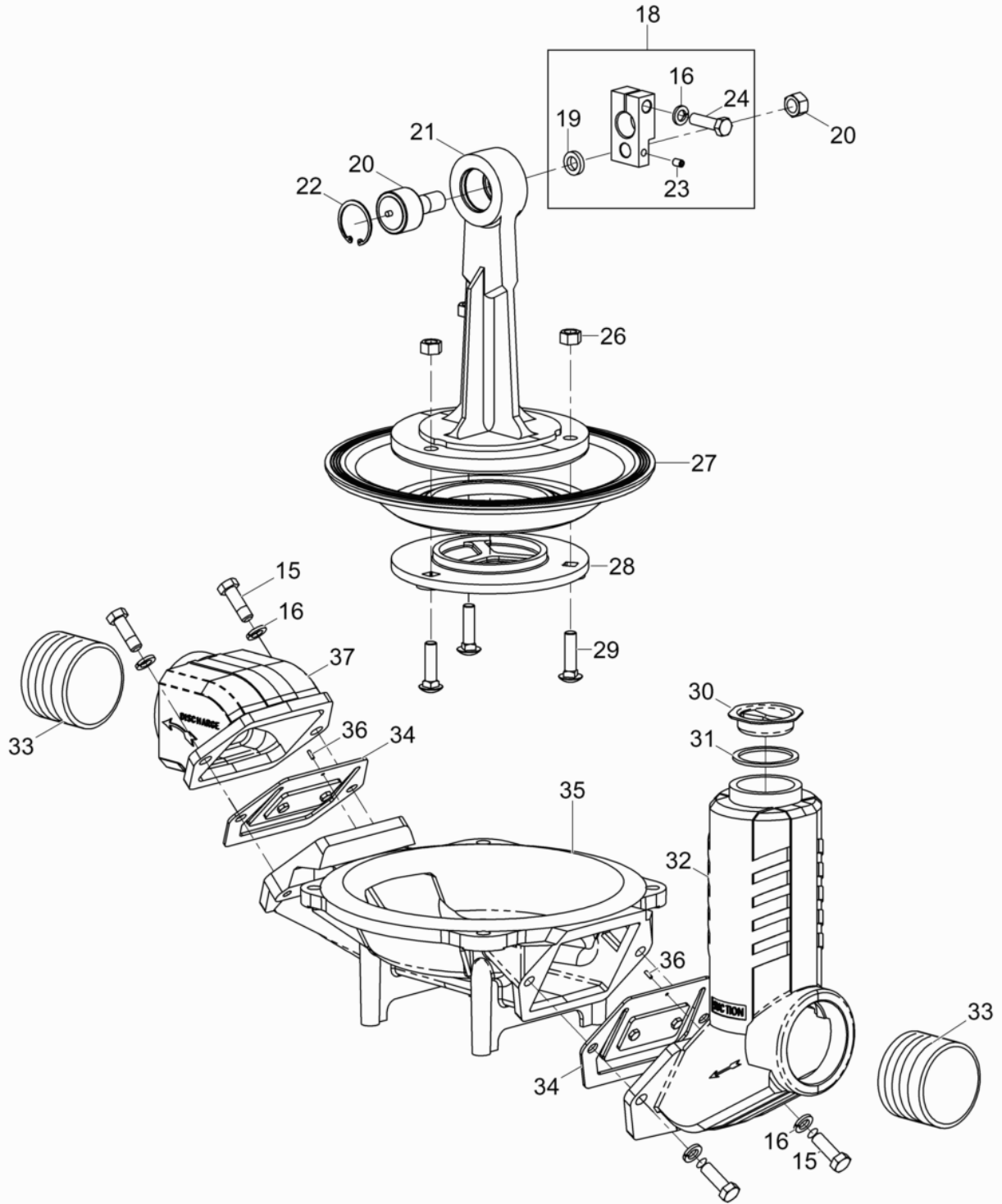

wc_ex0620773101_02

Ref. Pos.	Part No. Artikel Nr.	Qty. St.	Description Beschreibung	Descripción Description	Measurement./Abm.	Norm
					Torque/Drehm.	Sealant Schmierstoff
15	0179867	4	Bolt Bolzen	Perno Boulon	1/2-13 x 1-1/2in	
16	0179869	5	Lock washer Federring	Federring Rondelle de ressort	1/2in	
18	0186903	1	Crank Arm Kit Kurbelarmsatz	Juego de Brazo del cigueñal Jeu de Bras de manivelle		
19	0186902	1	Spacer Abstandsstück	Espaciador Entretoise	1/2-13 x 2-1/4in	
20	0179876	1	Bearing Lager	Rodamiento Roulement		
21	0179878	1	Arm Arm	Brazo Bras		
22	0179880	1	Retaining ring Sicherungsring	Anillo de retención Bague d'arrêt	1-3/4in	
23	0180232	1	Setscrew Gewindestift	Tornillo Vis	5/16-18 x 1/2in	
24	0186902	1	Spacer Abstandsstück	Espaciador Entretoise	1/2-13 x 2-1/4in	
26	0180236	3	Nut Mutter	Tuerca Écrou	1/2in-13	
27	0180238	1	Diaphragm Membran	Diafragma Membrane		
28	0180240	1	Retainer Halter	Retenedor Arrêtoir		
29	0180242	3	Carriage bolt Schloßschraube	Tornillo de carruaje Boulon brut à tête bombée		
30	0180244	1	Plug Stopfen	Tapón Bouchon		
31	0180245	1	Gasket Dichtung	Junta Joint		
32	0180246	1	Housing Gehäuse	Caja Carter		
33	0054151	2	Nipple fitting Stutzen	Niple Raccord	3in NPT/BSPT x 2-3/4	
34	0180254	2	Flapper valve gasket Prallplattendichtung	Empaquetadura Garniture		
35	0180256	1	Pump housing Pumpengehäuse	Caja de la bomba Carter de pompe		
36	0180258	2	Pin Stift	Pasador Goupille	1/8 x 3/8in	
37	0180259	1	Plate Platte	Placa Plaque		

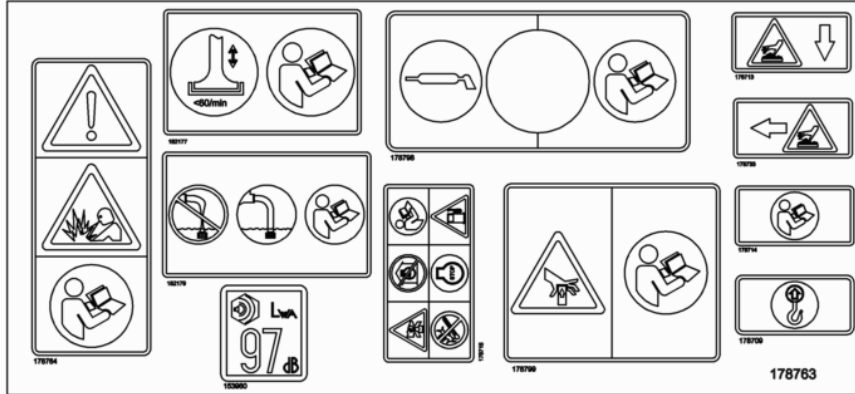

7

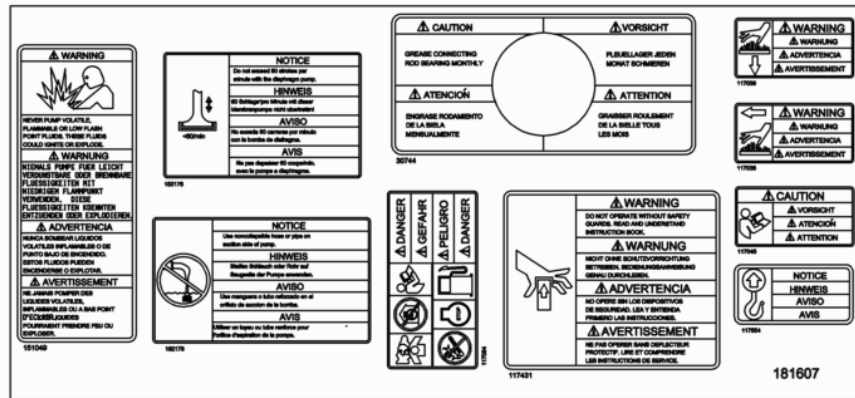

6

PD2 — 3

PD3 — 4



1

WACKER
NEUSON

2

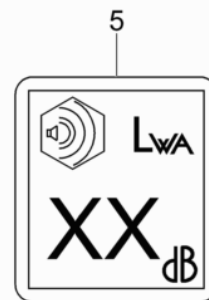

5

wc_ex0620769100_04

Ref. Pos.	Part No. Artikel Nr.	Qty. St.	Description Beschreibung	Descripción Description	Measurement./Abm.	Norm
					Torque/Drehm.	Sealant Schmierstoff
1	0222086	1	Label Symbol Aufkleber Symbol	Calcomania Símbolo Autocollant Symbole		
2	0222100	2	Label-Wacker Neuson logo Aufkleber-Wacker Neuson Logo	Calcomanía-Wacker Neuson logotipo Autocollant-Wacker Neuson logo	30	
3	0117541	2	Label Aufkleber	Calcomania Autocollant		
4	0117542	2	Label Aufkleber	Calcomania Autocollant		
5	0153960	1	Label Aufkleber	Calcomania Autocollant		
6	0181607	1	Label sheet Aufkleberblatt	Hoja de calcomanias Feuille d'autocollants		
7	0178763	1	Label sheet-EU Aufkleberblatt-EU	Hoja de calcomanias-EU Feuille d'autocollants-EU		



**WACKER
NEUSON**

**Engine-Honda
Honda-Motor
Motor Honda
Moteur Honda**

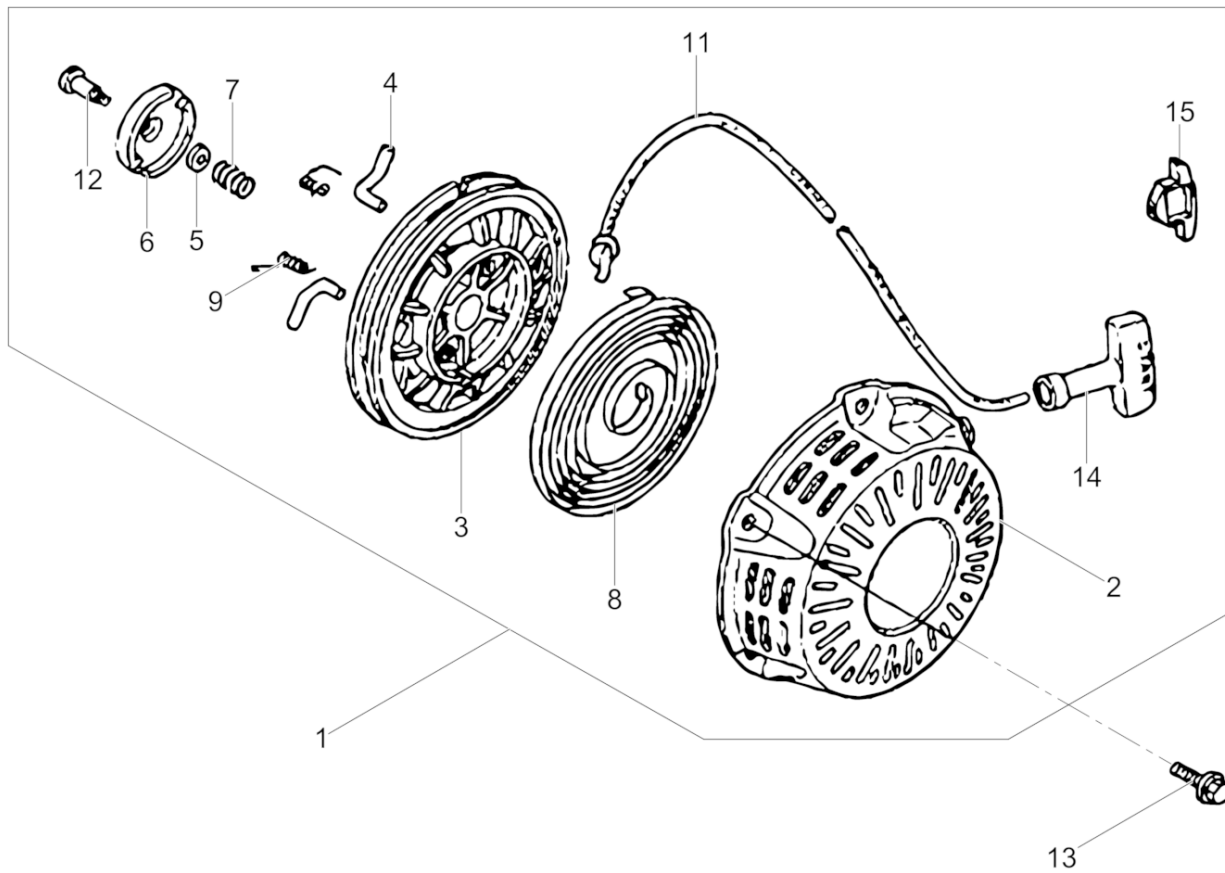

5100028819_01

Ref. Pos.	Part No. Artikel Nr.	Qty. St.	Description Beschreibung	Descripción Description	Measurement/Abm.	Norm
					Torque/Drehm.	Sealant Schmierstoff
1	5100005368	1	Starter cpl. US (red) Seilzugstarter kpl. US (rot)	Arrancador cpl. US (rojo) Démarrreur cpl. US (rouge)		
2	5100005369	1	Housing cpl. (red) Gehäuse kpl. (rot)	Carcasa cpl. (rojo) Enveloppe cpl. (rouge)		
3	5200006386	1	Starter reel (black) Seilscheibe (schwarz)	Disco de cuerda (negro) Disque pour corde (noir)		
4	0160527	2	Ratchet Ratsche	Trinquete Cliquet		
5	0160748	1	Friction Plate Reibplatte	Placa de Fricción Plaque à Friction		
6	0160745	1	Guide Führung	Guía Guide		
7	0160747	1	Friction spring Reibfeder	Resorte de Fricción Ressort à Friction		
8	0081777	1	Spring Feder	Resorte Ressort		
9	0207990	2	Spring Schenkelfeder	Resorte Ressort		
11	0081781	1	Rope Starterseil	Cuerda Corde		
12	0207991	1	Screw Schraube	Tornillo Vis		
13	0158458	3	Flange Bolt Flanschbolzen	Tornillo de Perno Vis de Boulon	6 x 10	
14	5100005309	1	Starter handle US Startergriff US	Empuñadura del starter US Poignée du lanceur US		
15	5200006389	1	Insert Einsatz	Inserto Insertion		

Ignition Coil
Zündspule
Bobina de Encendido
Bobine d'Allumage

PDI3A(I)

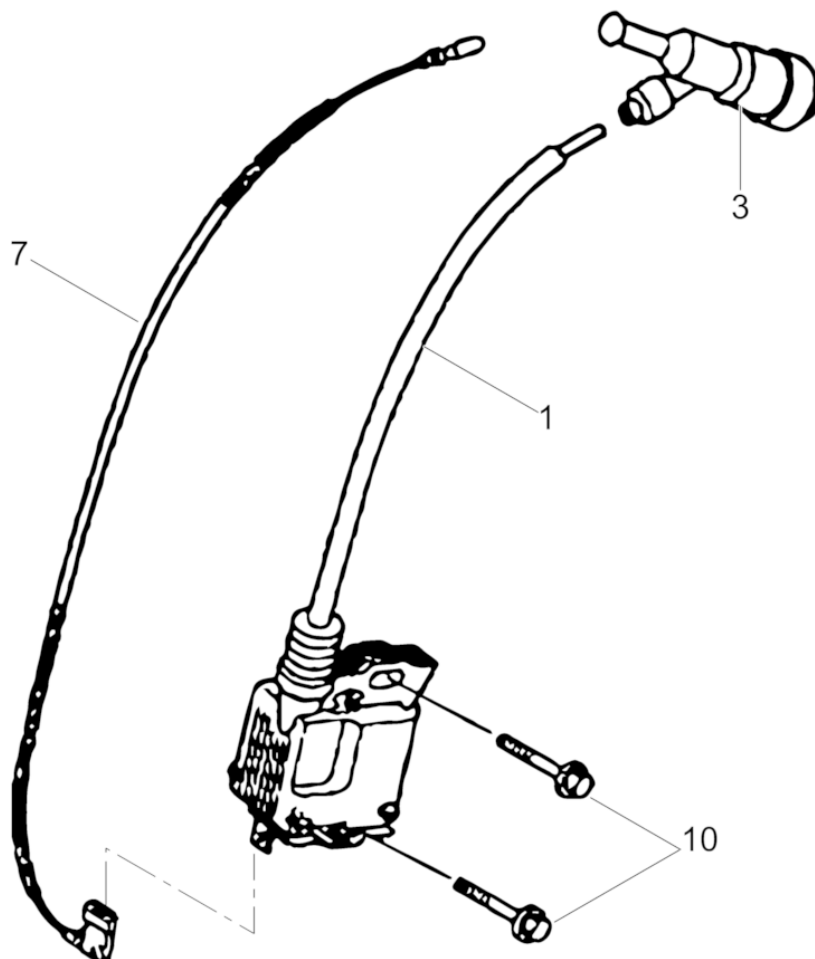

5100028822_01

Ref. Pos.	Part No. Artikel Nr.	Qty. St.	Description Beschreibung	Descripción Description	Measurement./Abm.	Norm
					Torque/Drehm.	Sealant Schmierstoff
1	0162679	1	Ignition Coil Zündspule	Bobina de Encendido Bobine d'Allumage		
3	0162680	1	Spark plug terminal cap Zündkerzenstecker	Enchufe de bujía Porte bougies		
7	0081663	1	Short circuit cable Kurzschlusskabel	Cable de cortocircuito Câble courti-circuit		
10	0081737	2	Screw Schraube	Tornillo Vis	M6 x 25	

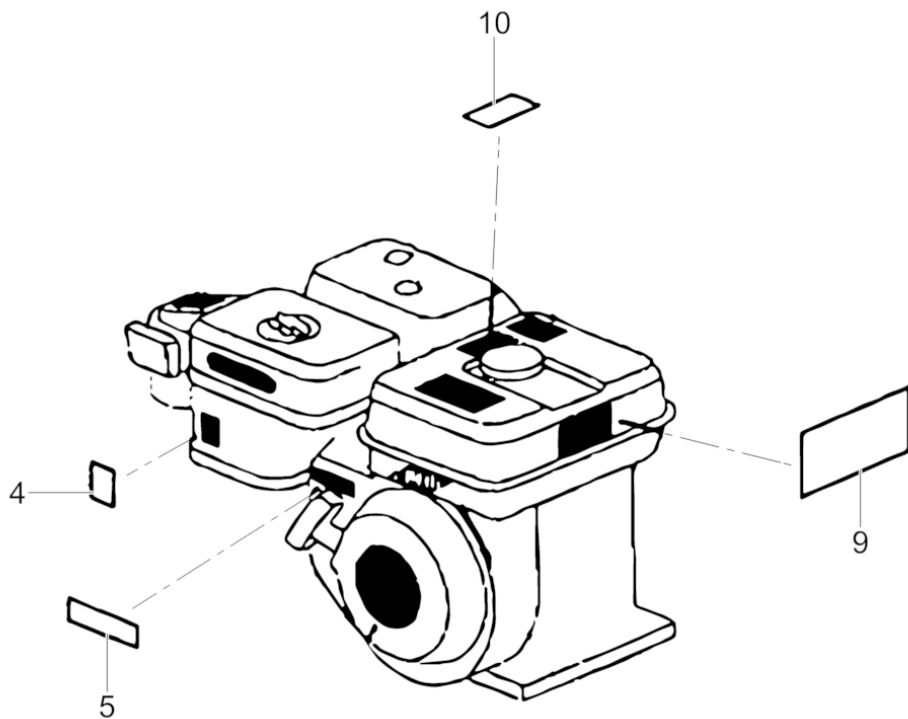

5100028836_01

Ref. Pos.	Part No. Artikel Nr.	Qty. St.	Description Beschreibung	Descripción Description	Measurement./Abm.	Norm
					Torque/Drehm.	Sealant Schmierstoff
4	5100005336	1	Label Aufkleber	Calcomanía Autocollant		
5	0208623	1	Labels Aufkleber	Calcomanias Autocollants		
9	5200000565	1	Label-operation Aufkleber-Betrieb	Calcomanía-Operación Autocollant-Opération		
10	5100005337	1	Label Aufkleber	Calcomanía Autocollant		

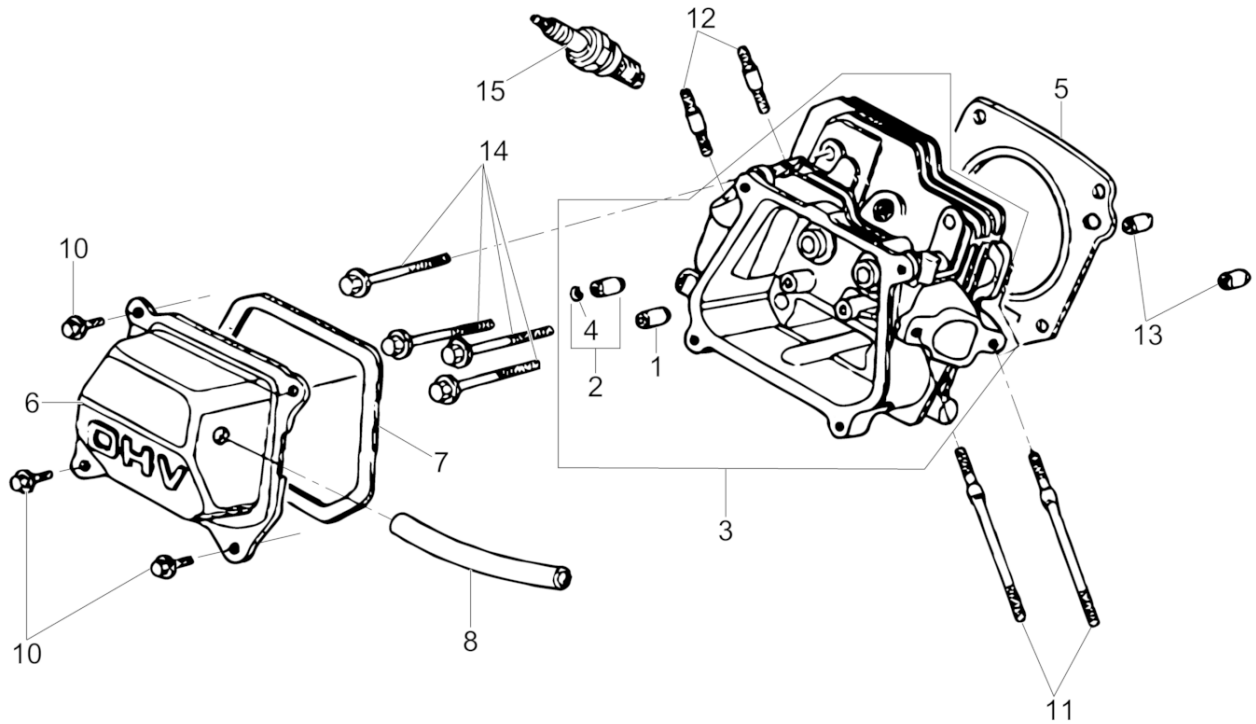

5100028813_01

Ref. Pos.	Part No. Artikel Nr.	Qty. St.	Description Beschreibung	Descripción Description	Measurement./Abm.	Norm
					Torque/Drehm.	Sealant Schmierstoff
1	0070945	1	Valve guide Ventilführung	Guía de válvula Guide de soupape		
2	0070944	1	Valve guide Ventilführung	Guía de válvula Guide de soupape		
3	0081786	1	Cylinder head Zylinderkopf	Culata Culasse		
4	0081744	1	Retaining ring Sicherungsring	Anillo de retención Bague d'arrêt		
5	0216514	1	Cylinder head gasket Zylinderkopfdichtung	Junta de culata del cilindro Joint de culasse de cylindre		
6	5200006482	1	Cylinder head cover Zylinderkopfhaube	Tapa del cilindro Couvercle supérieur		
7	0070942	1	Gasket Dichtung	Junta Joint		
8	0081761	1	Breather tube Entlüftungsrohr	Tubo respiradero Tube reniflard		
10	0053990	4	Screw Schraube	Tornillo Vis	M6 x 12 10Nm/7ft.lbs	
11	0406696	2	Stud Gewindebolzen	Perno prisionero Goujon		
12	0070948	2	Stud Gewindebolzen	Perno prisionero Boulon	M8 x 32	
13	0070950	2	Dowel pin Passstift	Espiga Cheville		
14	5100028591	4	Bolt Bolzen	Perno Boulon	M8x55	
15	0150914	1	Spark plug Zündkerze	Bujía Bougie		

Camshaft
Nockenwelle
Arbol de levas
Arbre à cames

PDI3A(I)

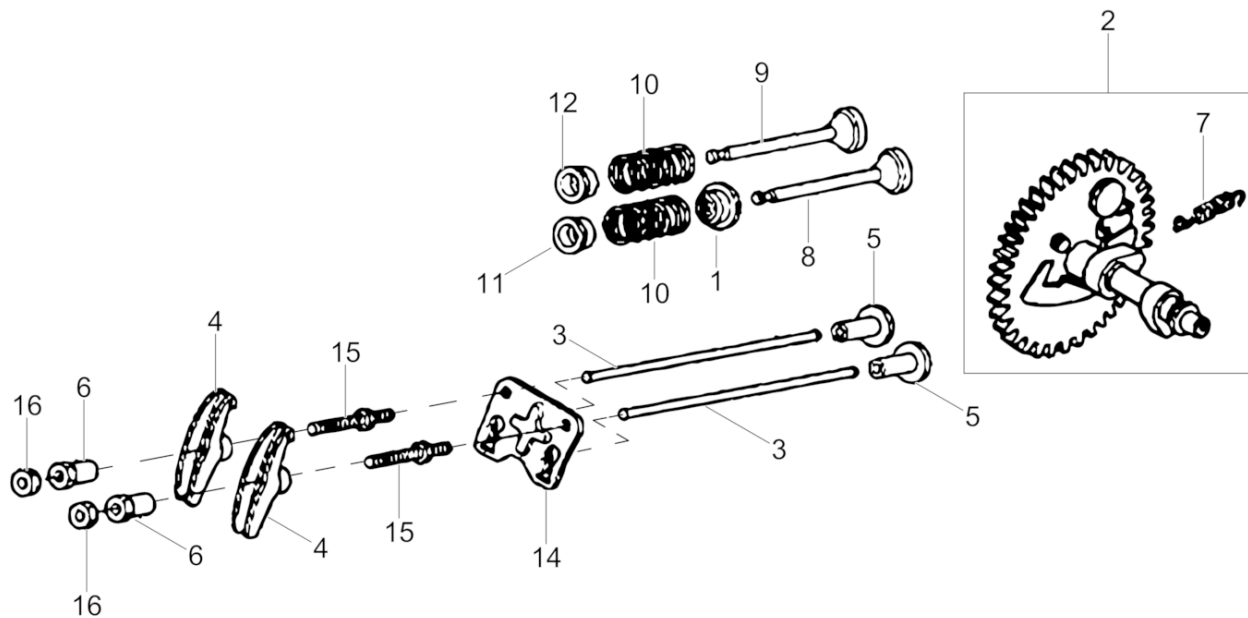

5100028818_01

Ref. Pos.	Part No. Artikel Nr.	Qty. St.	Description Beschreibung	Descripción Description	Measurement./Abm.	Norm
					Torque/Drehm.	Sealant Schmierstoff
1	520006507	1	Cylinder cpl. Zylinder kpl.	Cilindro compl. Cylindre compl.		
2	0072902	1	Camshaft Nockenwelle	Arbol de levas Arbre à cames		
3	0070989	2	Push rod (valve lifter) Stoßstange	Levantaválvula Poussoir de soupape		
4	0070986	2	Rocker arm Kipphebel	Balancín Culbuteur		
5	0070990	2	Valve tappet Ventilstößel	Levantaválvula Poussoir		
6	5100028592	2	Rocker arm pivot Einstellmutter	Espaciador Pivot		
7	0151028	1	Spring Feder	Resorte Ressort		
8	0406703	1	Intake valve Einlaßventil	Válvula de admisión Soupape d'admission		
9	5100028593	1	Exhaust valve Auslaßventil	Válvula de escape Soupape d'échappement		
10	0081760	2	Spring Feder	Resorte Ressort		
11	0070996	1	Holder Halter	Soporte Attache		
12	0070996	1	Holder Halter	Soporte Attache		
14	0070988	1	Plate Platte	Placa Plaque		
15	0072778	2	Stud Gewindebolzen	Perno prisionero Boulon	8	
16	0070984	2	Locknut Sechskantmutter	Contratuercas Contre-écrou	1/4-28in	

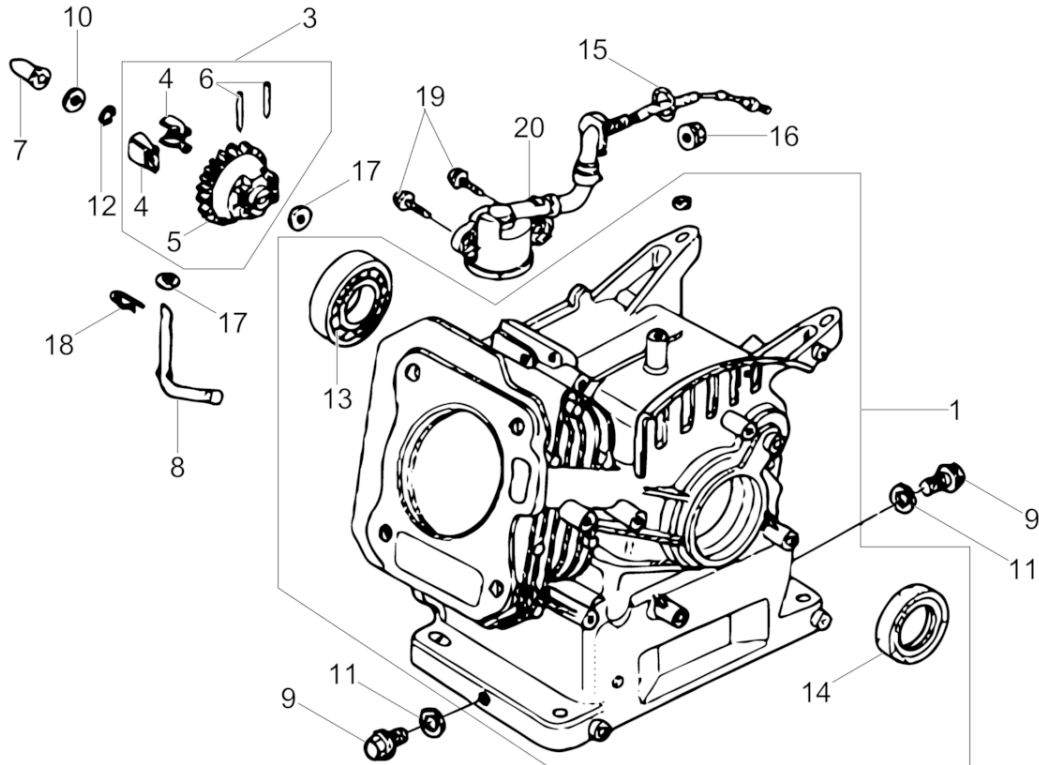

5100028814_01

Ref. Pos.	Part No. Artikel Nr.	Qty. St.	Description Beschreibung	Descripción Description	Measurem./Abm.	Norm
					Torque/Drehm.	Sealant Schmierstoff
1	0209782	1	Cylinder Zylinder	Cilindro Cylindre		
3	0076934	1	Governor cpl. Regler kpl.	Regulador compl. Régulateur compl.		
4	0151694	2	Weight Gewicht	Peso Poids		
5	0151695	1	Bracket Halter	Soporte Équerre		
6	0156689	2	Pin Stift	Espiga Goupille		
7	0070953	1	Slider Gleitstück	Manguito Douille		
8	0107060	1	Governor Reglerhebel	Regulador Régulateur		
9	0070964	2	Plug (threaded) Verschlusschraube	Tapón roscado Bouchon		
10	0070959	1	Washer Scheibe	Arandela Rondelle		
11	0070963	2	Washer Scheibe	Arandela Rondelle		
12	0081615	1	Retaining ring Sicherungsring	Anillo de retención Bague d'arrêt		
13	0070961	1	Grooved ball bearing Rillenkugellager	Rodamiento de bolas Roulement à billes		
14	0070962	1	Shaft seal Wellendichtring	Sello del eje Bague d'étanchéité		
15	0071082	1	O-Ring O-Ring	Anillo-O Joint torique	14 x 1,3	
16	0072332	1	Flange nut Flanschmutter	Tuerca de reborde Ecrou de bride	M10	
17	0071639	2	Washer Scheibe	Arandela Rondelle	6M	
18	0054033	1	Pin Stift	Pasador Goupille		
19	0072333	2	Screw Schraube	Tornillo Vis	M6 x 12 10Nm/7ft.lbs	
20	0216513	1	Oil alert switch cpl. Ölwarnschalter	Modulo-interruptor Module-contacteur		

Crankcase Cover
Kurbelgehäusedeckel
Tapa del Cárter
Couvercle de Carter

PDI3A(I)

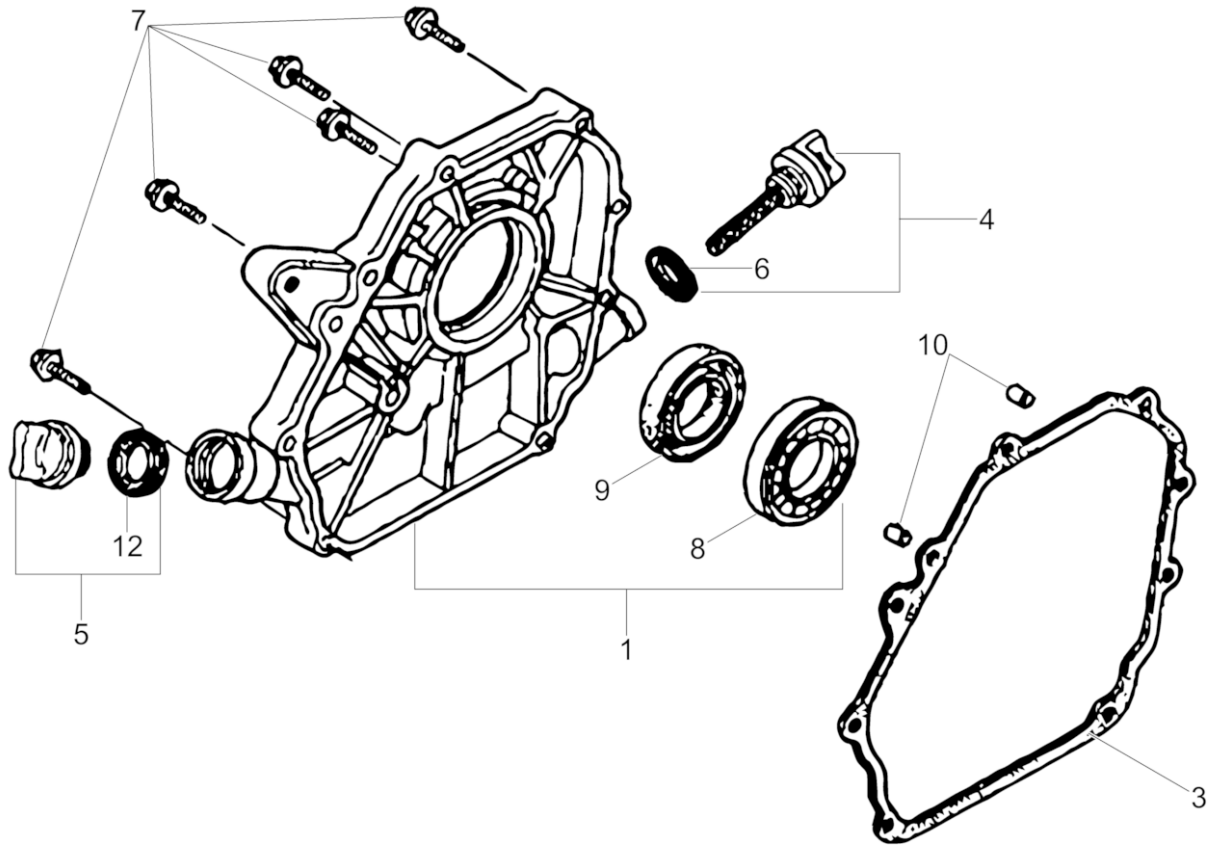

5100028815_01

Ref. Pos.	Part No. Artikel Nr.	Qty. St.	Description Beschreibung	Descripción Description	Measurement./Abm.	Norm
					Torque/Drehm.	Sealant Schmierstoff
1	0081740	1	Cover Deckel	Tapa Couvercle		
3	0081783	1	Gasket Dichtung	Junta Joint		
4	0162645	1	Dipstick assembly Peilstab kpl.	Indicador del nivel de aceite compl. Réglette-jauge compl.		
5	0162646	1	Oil filler cap Kappe-Ölfüller	Llenador de aceite Remplisseur d'huile		
6	0162647	1	Gasket Dichtung	Junta de estanqueidad Garniture		
7	0070966	7	Screw Schraube	Tornillo Vis	M6 x 28 10Nm/7ft.lbs	
8	0070961	1	Grooved ball bearing Rillenkugellager	Rodamiento de bolas Roulement à billes		
9	0070969	1	Shaft seal Wellendichtring	Sello del eje Bague d'étanchéité		
10	0053995	2	Dowel pin Passstift	Espiga Cheville	A8 x 14	
12	0162647	1	Gasket Dichtung	Junta de estanqueidad Garniture		

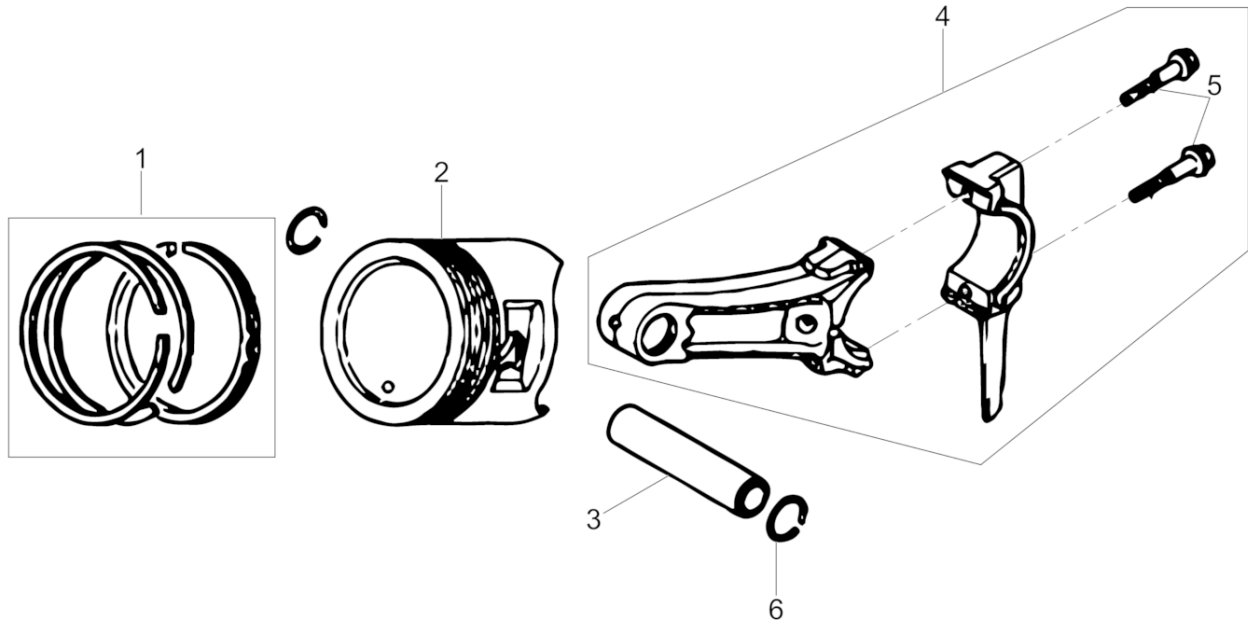

5100028817_01

Ref. Pos.	Part No. Artikel Nr.	Qty. St.	Description Beschreibung	Descripción Description	Measurement./Abm.	Norm
					Torque/Drehm.	Sealant Schmierstoff
1	5100028594	1	Piston Ring Set Kolbenringsatz	Juego de anillos Jeu de segments		
2	0213405	1	Piston Kolben	Pistón Piston		
3	0071008	1	Piston pin Kolbenbolzen	Pasador de pistón Axe de piston		
4	0209799	1	Connecting rod Pleuel	Biela Bielle		
5	0071007	2	Screw Schraube	Tornillo Vis	M7 x 35	
6	0081751	2	Retaining ring Sicherungsring	Anillo de retención Bague d'arrêt		

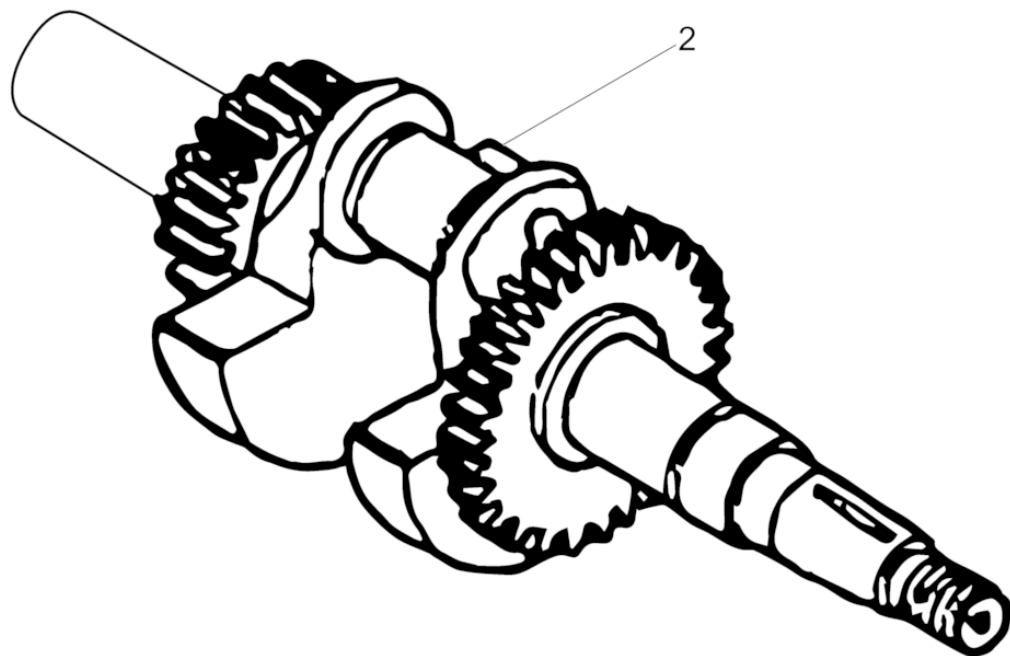

5100028816_01

Ref. Pos.	Part No. Artikel Nr.	Qty. St.	Description Beschreibung	Descripción Description	Measur./Abm.	Norm
					Torque/Drehm.	Sealant Schmierstoff
2	0216512	1	Crankshaft Kurbelwelle	Cigüeñal Vilebrequin		

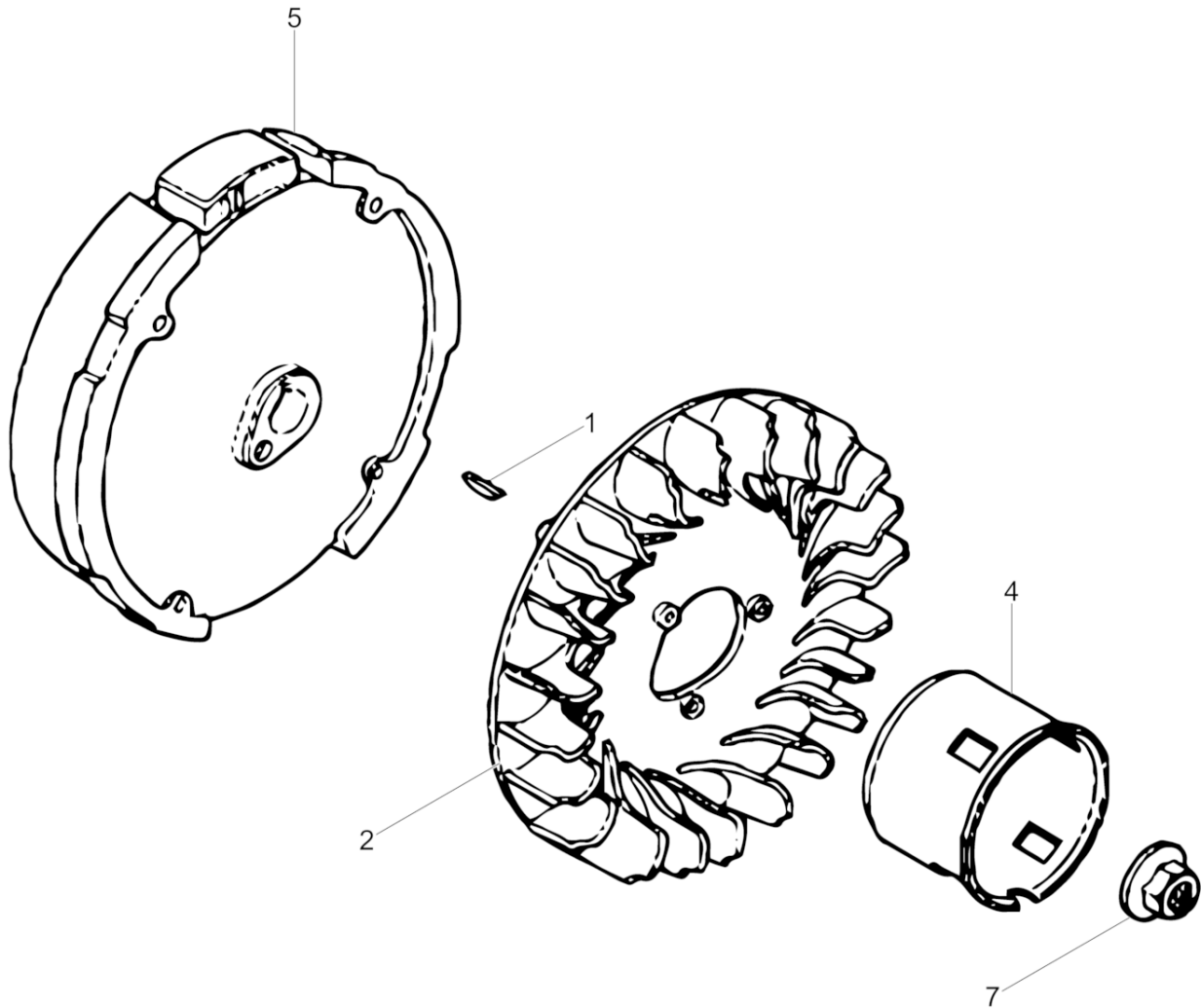

5100028821_01

Ref. Pos.	Part No. Artikel Nr.	Qty. St.	Description Beschreibung	Descripción Description	Measurement./Abm.	Norm
					Torque/Drehm.	Sealant Schmierstoff
1	0068967	1	Woodruff key Keil	Chaveta Woodruff Clavette Woodruff	25 x 18	
2	0070976	1	Fan Lüfterrad	Ventilador Ventilateur		
4	0160750	1	Starter Pulley Starterscheibe	Arandela Del Starter Rondelle du Lanceur		
5	0213410	1	Flywheel Schwungrad	Volante Volant		
7	0213410	1	Flywheel Schwungrad	Volante Volant		

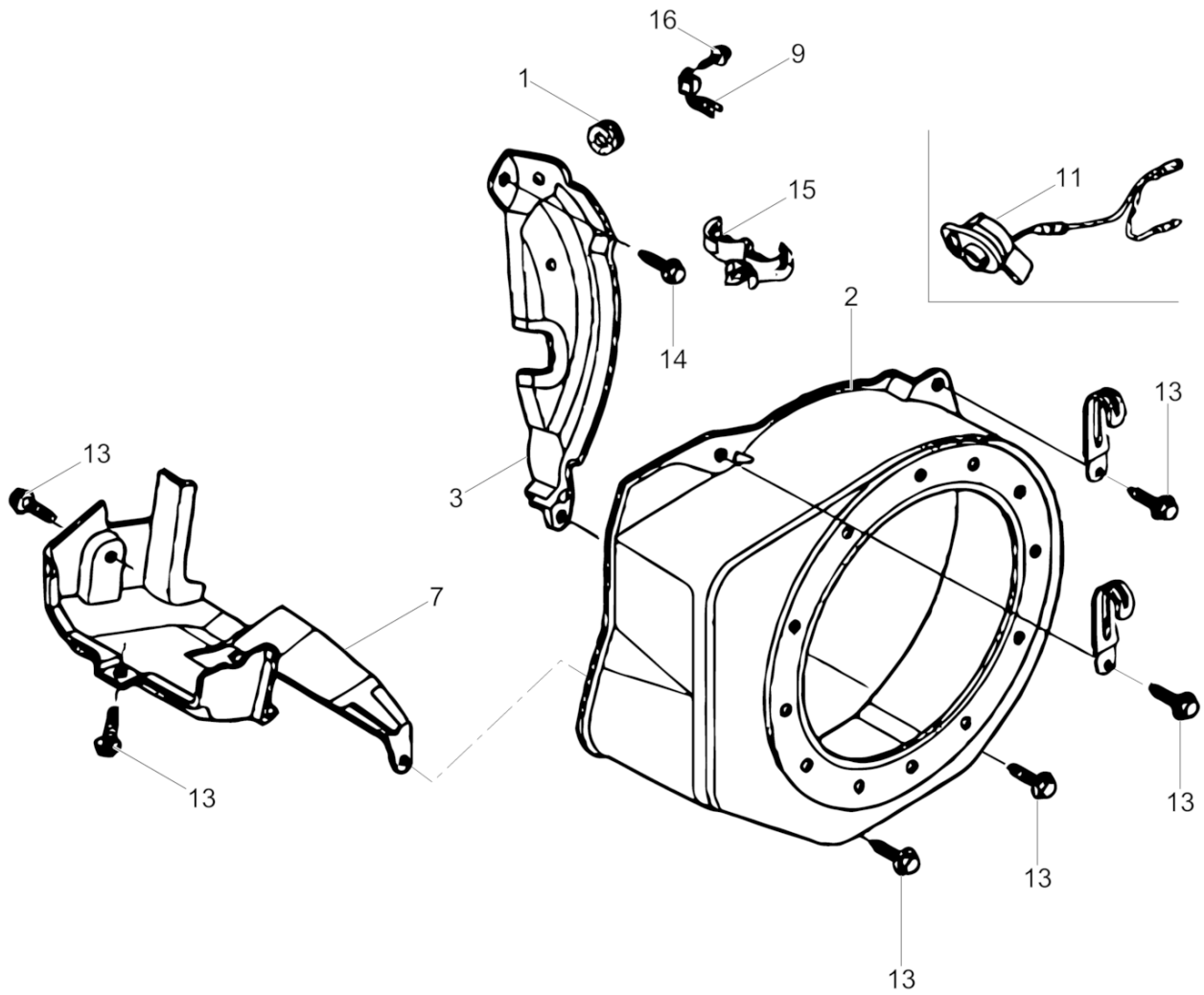

5100028820_01

Ref. Pos.	Part No. Artikel Nr.	Qty. St.	Description Beschreibung	Descripción Description	Measurement./Abm.	Norm
					Torque/Drehm.	Sealant Schmierstoff
1	0070979	1	Grommet Tülle	Ojal Passe-fil	0,315in	
2	0089353	1	Blower housing (shroud) Lüfterhaube	Cubierta Boîtier du ventilateur		
3	0153137	1	Plate Platte	Placa Plaque		
7	0153139	1	Duct Luftleitblech	Conducto de aire Canal d'air		
9	5100003471	1	Oil Sensor Ölsensor	Alerta de Aceite Alerte d'Huile		
11	0162682	1	Switch assembly Schalter kpl.	Interruptor compl. Interrupteur compl.		
13	0053990	6	Screw Schraube	Tornillo Vis	M6 x 12 10Nm/7ft.lbs	
14	0071055	1	Screw Schraube	Tornillo Vis	M6 x 20 10Nm/7ft.lbs	
15	0151700	1	Clamp Schelle	Abrazadera Attache		
16	0081750	1	Screw Schraube	Tornillo Vis	M6 x 8	

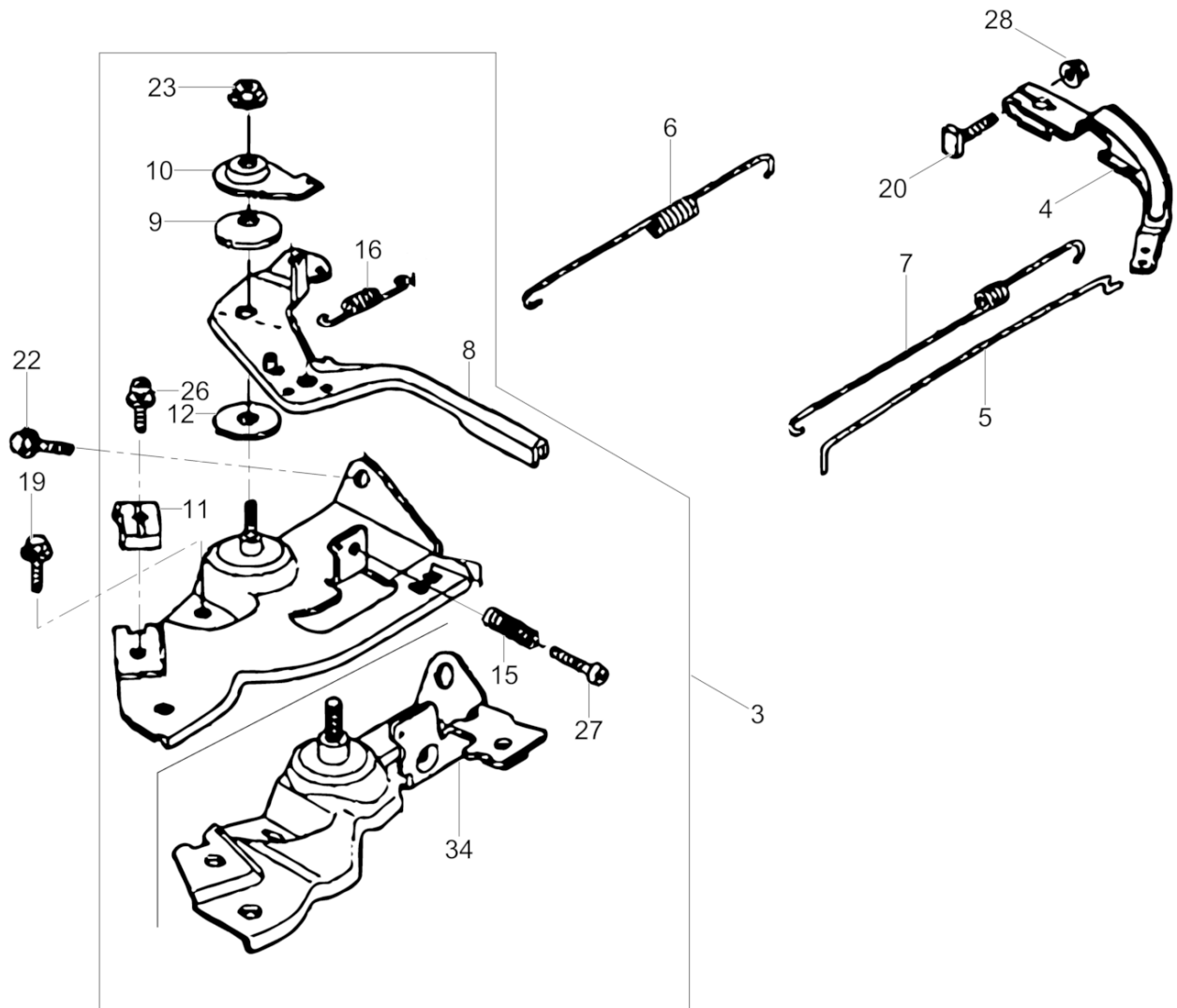

5100028827_01

Ref. Pos.	Part No. Artikel Nr.	Qty. St.	Description Beschreibung	Descripción Description	Measurement./Abm.	Norm
					Torque/Drehm.	Sealant Schmierstoff
3	5100028595	1	Control cpl. Betätigung kpl.	Regulador compl. Commande compl.		
4	0081742	1	Governor lever Regulierhebel	Palanca de regulador Levier régulateur		
5	0071068	1	Governor rod Reglerstange	Varillaje de regulación Tige de régulateur		
6	0081070	1	Governor spring Reglerfeder	Resorte del regulador Ressort régulateur		
7	0081743	1	Spring Feder	Resorte Ressort		
8	0406699	1	Lever Hebel	Palanca Levier		
9	0071058	1	Spring Feder	Resorte Ressort		
10	0071057	1	Washer Scheibe	Arandela Rondelle		
11	0071062	1	Cable holder Klemme	Soporte cable Attache		
12	0071064	1	Spacer Distanzstück	Espaciador Pièce d'écartement		
15	0054088	1	Adjusting spring Feder	Resorte de ajuste Ressort d'ajustage		
16	0071667	1	Spring Feder	Resorte Ressort		
19	0053990	1	Screw Schraube	Tornillo Vis	M6 x 12 10Nm/7ft.lbs	
20	0068966	1	Screw Schraube	Tornillo Vis		
22	0071055	1	Screw Schraube	Tornillo Vis	M6 x 20 10Nm/7ft.lbs	
23	0072782	1	Locknut Sicherungsmutter	Contratuerca Contre-écrou	M6	
26	0110112	1	Screw Schraube	Tornillo Vis	5 x 16	
27	0081990	1	Screw Schraube	Tornillo Vis	M5 x 25	
28	0071056	1	Nut Mutter	Tuerca Ecrou	M6	
34	5100028597	1	Muffler cover Auspufftopfabdeckung	Tapa del silenciador Couvercle de pot d'échappement		

Carburetor cpl.
Vergaser kpl.
Carburador compl.
Carburateur compl.

PDI3A(I)

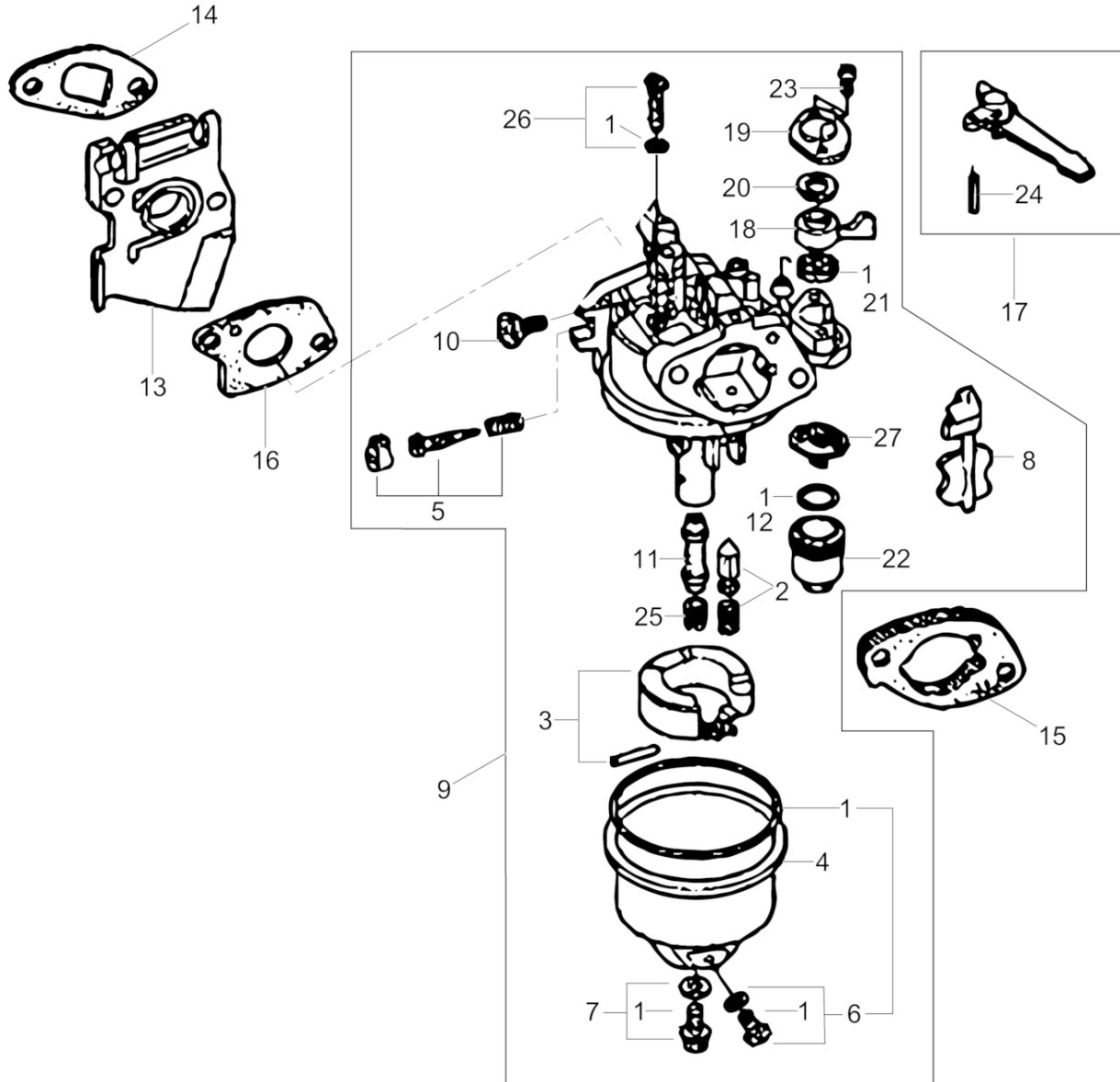

5100028826_01

Ref. Pos.	Part No. Artikel Nr.	Qty. St.	Description Beschreibung	Descripción Description	Measurem./Abm.	Norm
					Torque/Drehm.	Sealant Schmierstoff
1	0072781	1	Set-gaskets Dichtungssatz	Juego de juntas Jeu de joints		
2	0071022	1	Set-float valve Schwimmernadel kpl.	Válvula de flotador Pointeau du carburateur		
3	0209764	1	Set-carburetor float Schwimmer kpl.	Juego de flotador Jeu de flotteur		
4	5100005314	1	Float housing Schwimmergehäuse	Cámara de flotador Cuve à niveau constant		
5	0089286	1	Setscrew Gewindestift	Tornillo Vis		
6	5200000430	1	Screw w/washer Schraube mit Scheibe	Tornillo con arandela Vis avec rondelle		
7	5200000431	1	Screw w/washer Schraube mit Scheibe	Tornillo con arandela Vis avec rondelle		
8	0071025	1	Set-engine choke Chokesatz	Juego de estrangulador Jeu d'étrangleur		
9	0406688	1	Carburetor cpl. Vergaser kpl.	Carburador compl. Carbureteur compl.		
10	0071018	1	Throttle stop screw Anschlagschraube	Tornillo de tope Vis		
11	0089355	1	Main jet Hauptdüse	Gicleur principal Gicleur prinzipal		
12	0071024	1	Gasket Dichtung	Junta Joint		
13	0071010	1	Insulator Isolator	Aislador Isolant		
14	0081794	1	Gasket Dichtung	Junta Joint		
15	0071015	1	Spacer Distanzstück	Espaciador Pièce d'écartement		
16	0081762	1	Gasket Dichtung	Junta Joint		
17	0071013	1	Choke control lever Chokehebel	Palanca estranguladora Levier d'étrangleur		
18	0150266	1	Fuel valve lever Kraftstoffhahn	Palanca Levier		
19	0073269	1	Plate Platte	Placa Plaque		
20	0073270	1	Spring washer Federscheibe	Arandela elástica Rondelle à ressort		
21	0073272	1	Gasket Dichtung	Junta Joint		
22	0071023	1	Fuel filter Kraftstofffilter	Filtro de combustible Filtre à carburant		
23	5100005317	2	Screw Kegelkopfschraube 3x6	Tornillo Vis	3x6	
24	0071014	1	Pin Stift	Pasador Goupille	2 x 12	
25	0153141	1	Main jet Hauptdüse	Chicler principal Gicleur principal	58	

Carburetor cpl.
Vergaser kpl.
Carburador compl.
Carburateur compl.

PDI3A(I)

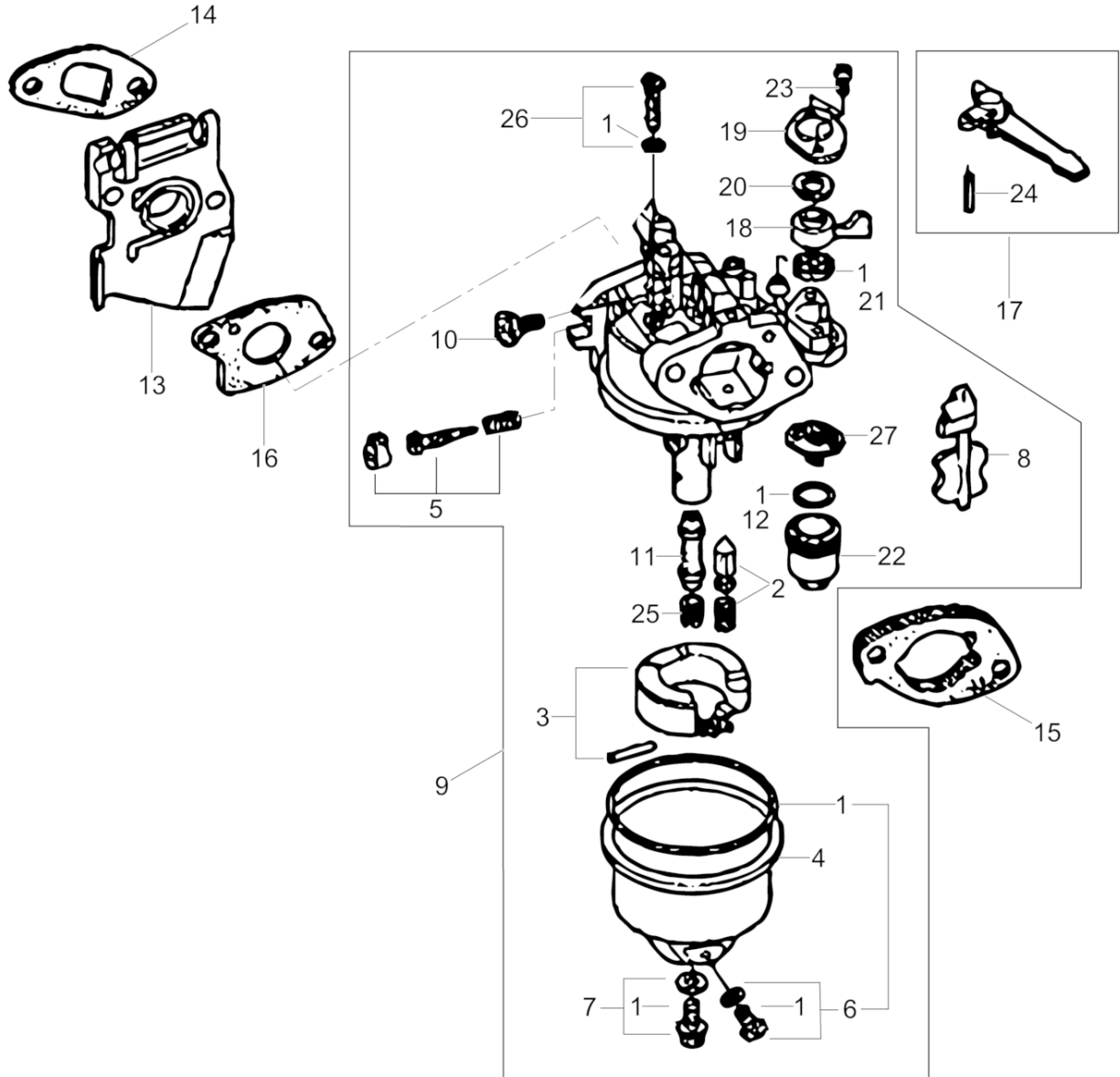

5100028826_01

Ref. Pos.	Part No. Artikel Nr.	Qty. St.	Description Beschreibung	Descripción Description	Measurem./Abm.	Norm
					Torque/Drehm.	Sealant Schmierstoff
25	0153140	1	Main jet Hauptdüse	Chicler principal Gicleur principal	55	
26	0071016	1	Pilot jet Leerlaufdüse	Chicler ralenti Gicleur de ralenti	35	
27	5100000396	1	Filter Filter	Filtro Filtre		

Fuel Tank cpl.
Kraftstofftank kpl.

PDI3A(I)

Depósito de Combustible compl.
Réservoir de carburant compl.

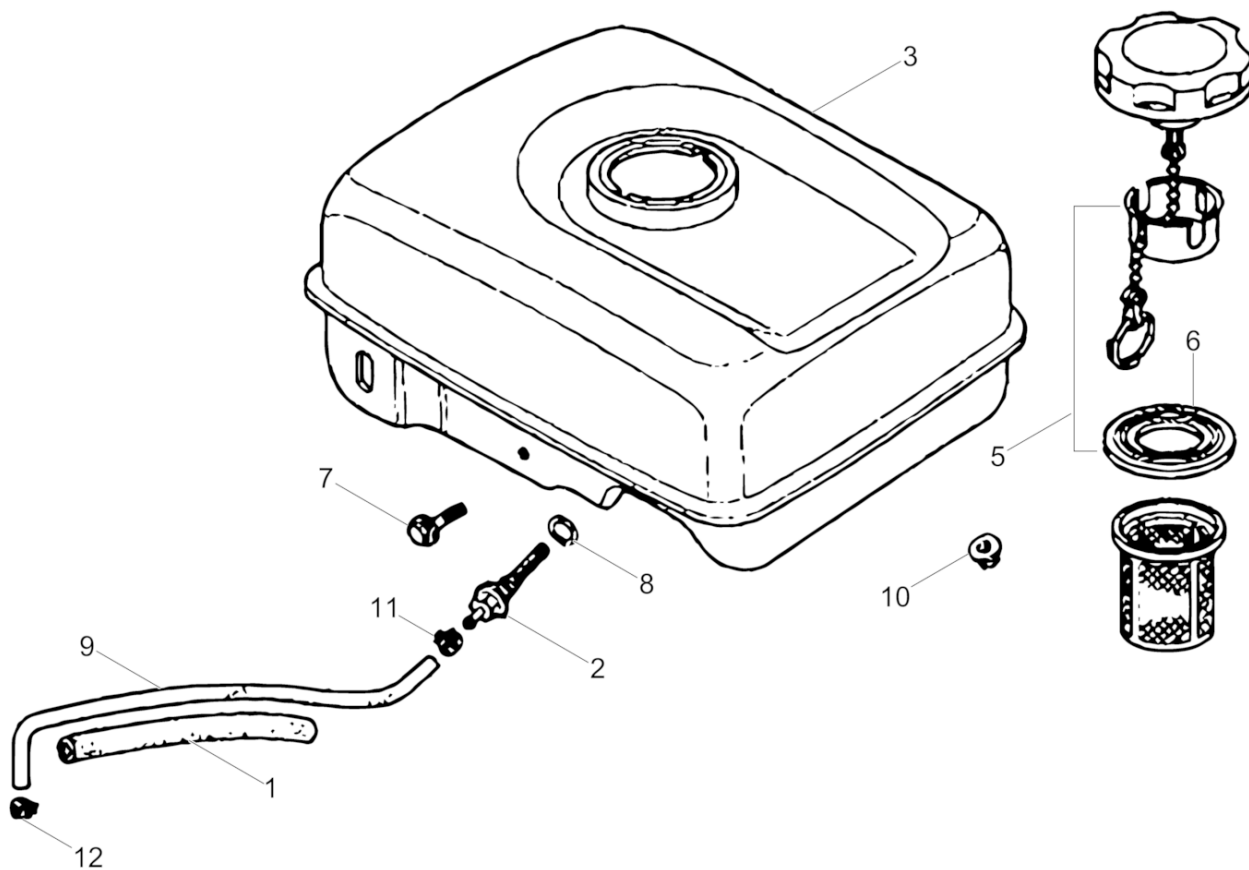

5100028825_01

Ref. Pos.	Part No. Artikel Nr.	Qty. St.	Description Beschreibung	Descripción Description	Measurement./Abm.	Norm
					Torque/Drehm.	Sealant Schmierstoff
1	0081764	1	Protective hose Schlauchstück	Manguera Tuyau		
2	0071083	1	Fuel filter Kraftstofffilter	Filtro de combustible Filtre à carburant		
3	5100030760	1	Fuel tank Kraftstofftank	Depósito de combustible Réservoir de carburant		
5	0217460	1	Cap-fuel fill Kraftstofftankverschluss	Tapa del tanque de combustible Chapeau de réservoir à essence		
5	5100005357	1	Tank cover cpl. Tankdeckel kpl.	Tapa de tanque cpl. Couvercle du reservoir cpl.		
6	0209770	1	Gasket Dichtung	Junta de estanqueidad Garniture		
8	0209771	1	Flange Bolt Flanschbolzen	Tornillo de Perno Vis de Boulon	6x29	
9	0071082	1	O-Ring O-Ring	Anillo-O Joint torique	14 x 1,3	
10	0209773	1	Fuel hose Kraftstoffschlauch	Manguera de combustible Tuyau à essence	4,5x140	
11	0071056	2	Nut Mutter	Tuerca Ecrou	M6	
12	0208617	2	Clamp Rohrschelle	Abrazadera Agrafe		

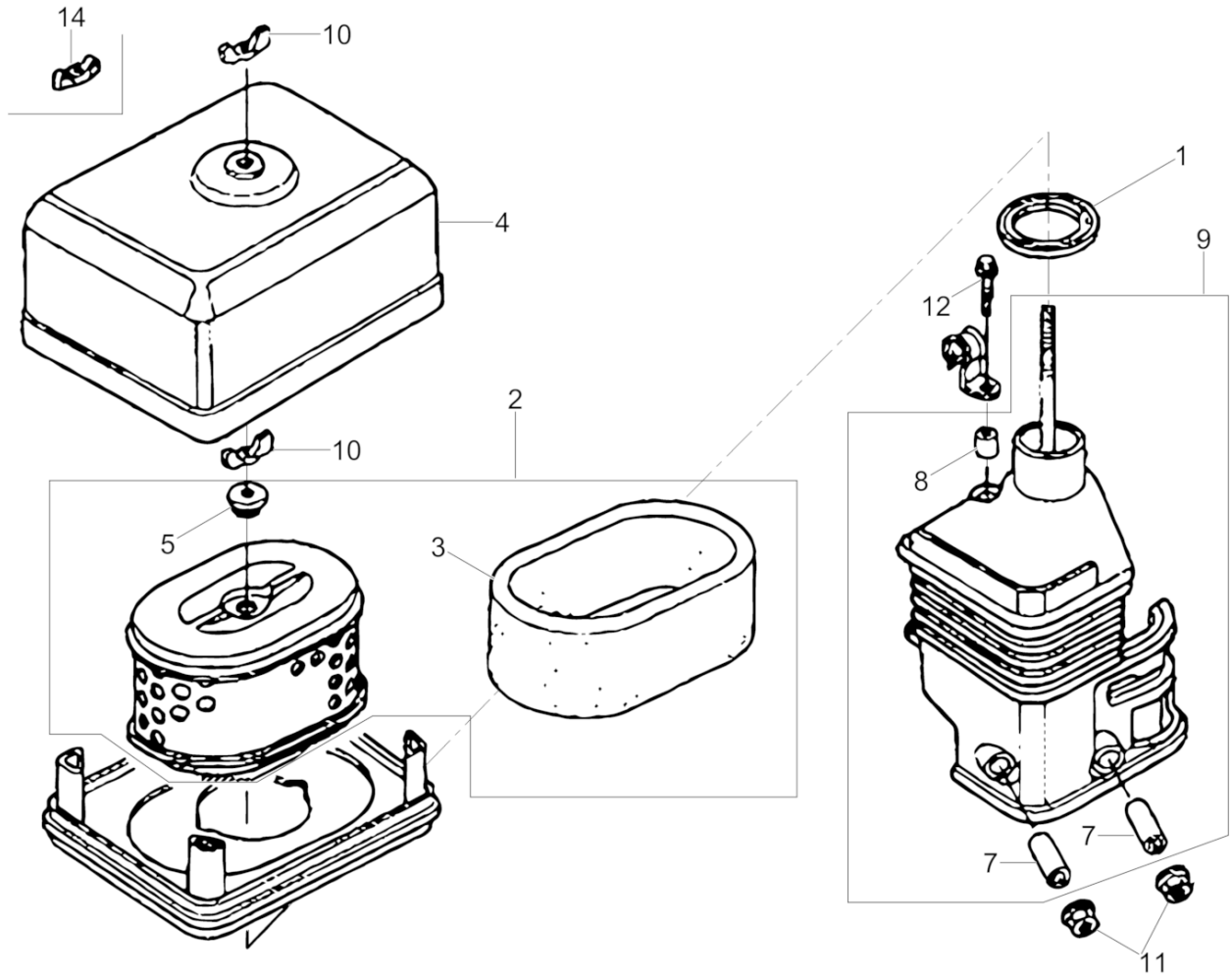

5100028824_01

Ref. Pos.	Part No. Artikel Nr.	Qty. St.	Description Beschreibung	Descripción Description	Measurem./Abm.	Norm
					Torque/Drehm.	Sealant Schmierstoff
1	0071032	1	Gasket Dichtung	Junta Joint		
2	0072314	1	Air cleaner element Luftfiltereinsatz	Elemento-filtro Élément filtrant		
3	0076941	1	Prefilter element Vorfilter	Elemento del prefiltro Élément du prénettoyeur		
4	5100028568	1	Air cleaner cover Luftfilterdeckel	Tapa-filtro del aire Couvercle-filtre à air		
4	0406689	1	Cover Deckel	Tapa Couvercle		
5	0072343	1	Grommet Tülle	Ojal Passe-fil		
7	0081746	2	Sleeve Hülse	Collar Douille		
8	0071035	1	Sleeve Hülse	Manguito Douille		
9	5100028569	1	Elbow cpl. Krümmer kpl.	Codo compl. Coude compl.		
10	0071621	1	Wing nut Flügelmutter	Tuerca mariposa Ecrou papillon	M6	
11	0071056	2	Nut Mutter	Tuerca Ecrou	M6	
12	5100003499	1	Flange screw Flanschschraube 6X20	Tornillo de brida Vis de bride	6x20	
14	5200006435	1	Wing nut Flügelmutter	Tuerca de mariposa Écrou à oreilles	M6	

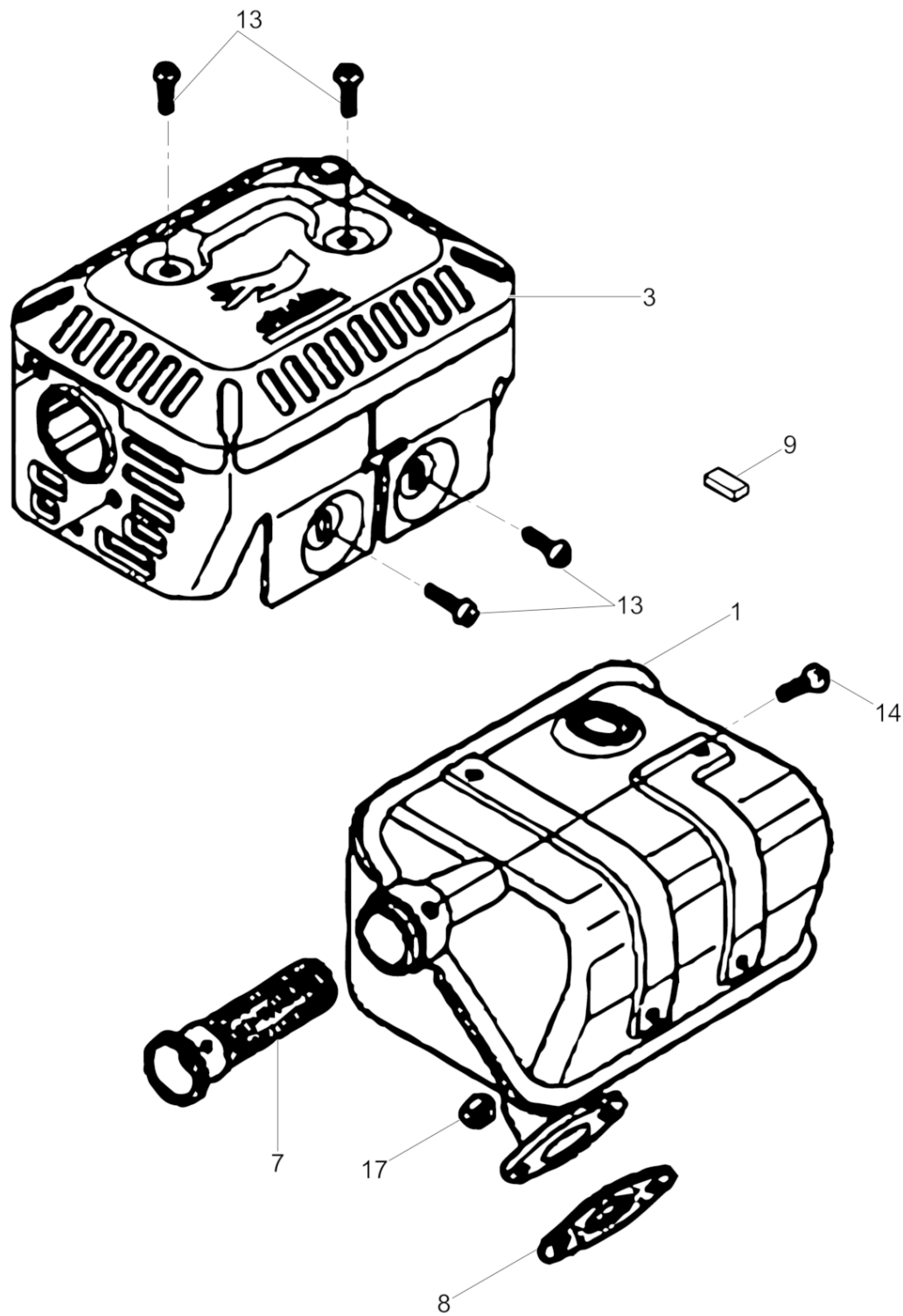

5100028823_01

Ref. Pos.	Part No. Artikel Nr.	Qty. St.	Description Beschreibung	Descripción Description	Measurement./Abm.	Norm
					Torque/Drehm.	Sealant Schmierstoff
1	5100028599	1	Muffler cpl. Auspufftopf kpl.	Silenciador compl. Pot d'Echappement compl.		
3	5200006438	1	Guard Schutz	Protector Protection		
7	0071075	1	Spark arrester Funkenfänger	Parachispas Pare-étincelles		
8	0216516	1	Gasket Dichtung	Junta de estanqueidad Garniture		
9	0070999	1	Fitting key Passfeder	Chaveta Clavette	4,78 x 38	
13	0071070	4	Screw Schraube	Tornillo Vis	M5 x 8	
14	0150916	1	Screw Schraube	Tornillo Vis	M4x6	
17	0071076	2	Nut Mutter	Tuerca Ecrou	M8	



**WACKER
NEUSON**